

**952NX**  
Vibratory Compactor

**OPERATOR'S MANUAL**

**Part number 92247124**  
1<sup>st</sup> edition English  
April 2025



# Contents

---

## 1 GENERAL INFORMATION

Note to the Owner .....	1-1
Intended use.....	1-2
Electro-magnetic compatibility (EMC).....	1-2
Telematics .....	1-2
Manual scope and required training level .....	1-3
Product Identification Number (PIN).....	1-5
Machine orientation.....	1-8
Machine components.....	1-9

## 2 SAFETY INFORMATION

Safety rules and signal word definitions .....	2-1
Safety rules .....	2-2
Ecology and the environment .....	2-6
Hand signals.....	2-7
Safety rules - Utility precautions - Utility precautions .....	2-9
Safety rules - Fuel handling precautions - Fuel handling precautions .....	2-9
Safety rules - Specific precautions to this machine .....	2-10
Safety signs .....	2-11
General safety rules .....	2-21

## 3 CONTROLS AND INSTRUMENTS

### Access to operator's platform

Warnings and preliminary checking .....	3-1
Access to operator's platform .....	3-1
Operator's seat .....	3-2

### Forward controls

Forward controls.....	3-4
Vandalism protection cover.....	3-5
Control panel switches .....	3-6
Instrument cluster panel .....	3-12

### Telematics

Telematics .....	3-19
------------------	------

## 4 OPERATING INSTRUCTIONS

### Commissioning the unit

Commissioning operation .....	4-1
Before using the machine .....	4-2
Operating the machine .....	4-3

---

## Starting the unit

Starting the unit.....	4-4
------------------------	-----

## Stopping the unit

Stopping the unit .....	4-6
-------------------------	-----

## Moving the unit

Moving the unit .....	4-7
-----------------------	-----

Machine and operator visibility .....	4-8
---------------------------------------	-----

## 5 TRANSPORT OPERATIONS

### Preparing for road transport

Transport dimensions.....	5-1
---------------------------	-----

### Shipping transport

Transporting on a trailer .....	5-1
---------------------------------	-----

Lifting points .....	5-3
----------------------	-----

### Recovery transport

Towing the machine .....	5-4
--------------------------	-----

## 6 WORKING OPERATIONS

### General information

Operating the machine during running-in period .....	6-1
--	-----

Operating the machine at high altitudes.....	6-1
--	-----

Operating the machine at high temperatures and humidity .....	6-1
---	-----

Operating the machine at low temperatures .....	6-2
---	-----

Operating the machine in extremely dusty environment .....	6-2
--	-----

Operating with vibration on compacted and hard materials .....	6-3
--	-----

### WORKING OPERATIONS

Water pump safety measures in cold regions .....	6-4
--	-----

Operating the machine .....	6-5
-----------------------------	-----

## 7 MAINTENANCE

### General information

Preventive maintenance.....	7-1
-----------------------------	-----

Engine inspection door - Open/Close .....	7-1
---	-----

Fuel tank.....	7-2
----------------	-----

Hydraulic oil tank .....	7-2
--------------------------	-----

Water tank .....	7-3
------------------	-----

Consumables.....	7-3
------------------	-----

Organic Acid Technology (OAT) coolant.....	7-4
--	-----

---

Engine oil temperature chart .....	7-5
Diagnostic/Service tool port .....	7-6

## Maintenance planning

Maintenance chart .....	7-7
-------------------------	-----

## At warning message display

Water separator drain .....	7-9
-----------------------------	-----

## Every 10 hours or daily

Fuel tank level - Check .....	7-9
Engine parameter display - Check .....	7-10
Engine oil level and oil leakage - Check.....	7-10
Engine coolant level - Check .....	7-12
Hydraulic oil level - Check .....	7-12
Grease points - Lubricate.....	7-13
Air restriction / vacuum indicator - Check .....	7-14
Parking brake.....	7-14
Visual inspection.....	7-14
Functionality of controls and lamps.....	7-14
Water present in fuel filter - Check and Drain .....	7-15
Fan belt tension - Check .....	7-15

## First 50 hours or 15 days

Mounting bolts of Roller, Front and rear cross beam, Side plates - Check and tighten	7-18
Scraper - Adjust .....	7-18
Operator platform, Canopy, Articulation joint mounting bolts - Check and tighten ....	7-19
Engine mounting bolts - Check and tighten .....	7-20

## Every 100 hours or 20 days

Hydraulic system breather - Cleaning .....	7-20
Engine, canopy and Operator platform mounting bolts - Check.....	7-21
Battery electrolyte level - Check.....	7-21
Battery terminals - Check and lubricate (if required) .....	7-22
Radiator and CAC hoses and clamps - Check and tighten (if required).....	7-22

## First 150 hours

Travel Reduction gearbox oil - Replace .....	7-23
--	------

## Every 250 hours or every 3 months

Drain off water and deposits from the fuel tank .....	7-23
---	------

## Every 500 hours or 6 months

Water pump and its related mounting bracket bolts - Check and tighten .....	7-24
Hydraulic oil filter - Replace .....	7-24

---

Pre-filter - Replace .....	7-25
Fan mounting bolts - Check and tighten.....	7-25
Engine oil and oil filter - Change .....	7-26
Fuel filters - Replace .....	7-27
Radiator mounting bolts - Check and tighten.....	7-28
Battery cells voltage and specific gravity - Check .....	7-29
Radiator, HOC and CAC fins - Cleaning .....	7-29
Fuel strainer - Clean.....	7-30
Baby filter - Replace.....	7-31
Drain water from hydraulic tank .....	7-31

## Every 1000 hours or 12 months

Exhaust pipe mounting - Check and tighten.....	7-32
Cuts and Damage in Wiring harness – Check .....	7-32
Drum oil - Replace.....	7-32
Exhaust gas leakage check on all V band clamps .....	7-33
Turbocharger mounting - Check.....	7-33
Engine and cooling pack mounting rubber pad - Check and replace .....	7-33
Travel Reduction gear box oil - Replace .....	7-34

## Every 1500 hours or 18 months

Fuel hoses - Check and replace.....	7-35
Fan belt - Replace.....	7-35

## Every 2000 hours

Drum bearing - Grease.....	7-36
Hydraulic oil - Replace .....	7-36
Engine coolant - Replace.....	7-37
Suction Strainer - Clean .....	7-38

## Every 4000 hours

Diesel Oxidation Catalyst (DOC) assembly - Replace .....	7-39
--	------

## As required

Water separator drain .....	7-39
Engine air filter primary and secondary element - Replace .....	7-40
Radiator, CAC - Cleaning whenever chocked .....	7-41
Fan / alternator belt - Replace.....	7-41
Water sprinkling system - Cleaning.....	7-42
Electrical systems - Check .....	7-42
Bleed air from the fuel system.....	7-42
ATS V-clamps and gaskets - Replace .....	7-42
Fuel strainer - Clean.....	7-43

## Storage

Storing the machine .....	7-44
---------------------------	------

---

Short term storage.....	7-45
Storing the engine .....	7-45
Battery storage .....	7-47
Taking the machine back to service .....	7-48

## 8 TROUBLESHOOTING

### Fault code resolution

Engine - Troubleshooting.....	8-1
Starter motor - Troubleshooting .....	8-3
Alternator - Troubleshooting.....	8-3
Hydraulic systems - Troubleshooting.....	8-4
Gearbox - Troubleshooting .....	8-7

## 9 SPECIFICATIONS

Machine dimensions.....	9-1
Operating weights .....	9-2
Vibration system.....	9-2
Engine specifications .....	9-2
Propulsion .....	9-3
Exciter drive .....	9-3
Steering system .....	9-3
Electrical system .....	9-4
Hydraulic oil filter .....	9-4
Brakes .....	9-4
Sprinkling .....	9-4
Relief valve settings .....	9-4
Special torques .....	9-5
Torque specifications .....	9-6

---

# 1 - GENERAL INFORMATION

## Note to the Owner

Congratulations! You are now the proud owner of CASE CONSTRUCTION vibratory compactor. All the components of this unit have been thoroughly checked and tested to meet the standards of quality and reliability you are entitled to expect in the field.

Your machine will remain a highly profitable tool provided you observe & maintain the operating and servicing recommendations outlined in this manual carefully, which covers the following items:

- Features and specifications of the machine
- Operation
- Basic safety rules
- Maintenance and Consumable
- Basic diagnostic information of hydraulic, mechanical and electrical systems.

Read this manual before you start the engine or operate the machine. If you need more information, contact your CASE CONSTRUCTION dealer.

This manual contains important information about safe operation, adjustment, and maintenance of your vibratory compactor. This manual is divided into chapters as outlined in the table of contents. Refer to the index at the end of this manual for locating specific items about your machine. The CASE CONSTRUCTION vibratory compactor conforms to current safety regulations. Read this manual carefully, paying particular attention to the instructions concerning safety, operation and maintenance so as to avoid the risk of injury while operating or servicing the machine.

**NOTE:** All persons who will be operating this machine shall possess a valid local vehicle operating permit and/or other applicable local age work permits.

The machine has been designed and manufactured according to the strictest quality standards. However, the risk of accidents can never be completely excluded. That is why it is essential to observe elementary safety rules and precautions. DO NOT operate or permit anyone to operate or service this machine until you or the other persons have read and understood the safety, operation, and maintenance instructions in this manual. Use only trained operators who have demonstrated the ability to operate and service this machine correctly and safely.

The information in this manual is provided on the basis of information that was available at the time that the manual was printed. Settings, procedures, part numbers, software, and other items can change. These changes can affect the service that is given to the machine. Make sure that you have the complete and most current information from your dealer before you start any machine operation.

The Operator's Manual is to be stored in the defined place equipped on this machine. Make sure this manual is complete and in good condition. Consult your dealer to obtain additional manuals or manuals in other languages.

Contact your dealer for any further information or assistance about your machine. Your dealer has CASE CONSTRUCTION approved service parts. Your dealer has technicians with special training who know the best methods of repair and maintenance for your machine.

**NOTE:** In any circumstances no part or the whole of this manual can be copied or reprinted without the written permission of CASE CONSTRUCTION Equipment (India) private limited.

**ATTENTION:** The fuel system and engine on your machine are designed and built to government emissions standards. Tampering by dealers, customers, operators, and users is strictly prohibited by law. Failure to comply could result in government fines, rework charges, invalid warranty, legal action and possible confiscation of the machine until rework to original condition is completed. Engine service and/or repairs must be done by a certified technician only!

## Intended use

This vibratory compactor is intended for compaction activities using externally induced vibrations.

Do not use this machine for any other purpose or in any manner other than as described in the manual, decals, or other product safety information provided with the machine. These materials define the machine's intended use.

All persons who will be operating this machine shall possess a valid local vehicle operating permit and/or other applicable local age work permits.

Consult an authorized dealer or CASE CONSTRUCTION Equipment (India) Pvt. Ltd. on changes, additions, or modifications that can be required for this machine to comply with various country regulations and safety requirements. Unauthorized modifications will cause serious injury or death. Anyone making such unauthorized modifications is responsible for the consequences.

**ATTENTION:** *The fuel system and engine on your machine are designed and built to government emissions standards. Tampering by dealers, customers, operators, and users is strictly prohibited by law. Failure to comply could result in government fines, rework charges, invalid warranty, legal action, and possible confiscation of the machine until rework to original condition is completed. Engine service and/or repairs must be done by a certified technician only.*

## Electro-magnetic compatibility (EMC)

Interference may arise as a result of add-on equipment that may not necessarily meet the required standards. As such interference can result in serious malfunction of the unit and/or create unsafe situations, you must observe the following:

- The maximum power of emission equipment (radio, telephones, etc.) must not exceed the limits imposed by the national authorities of the country where you use the machine.
- The electro-magnetic field generated by the add-on system should not exceed at any time and at any location in the proximity of electronic components.
- The add-on equipment must not interfere with the functioning of the on board electronics.

Failure to comply with these rules will render the CASE CONSTRUCTION warranty null and void.

**NOTICE:** *This machine incorporates CAN network data busses for communication within the vehicle, and offboard diagnostics. Do not add or remove devices on the CAN networks, or modify the CAN network wiring, unless specifically authorized by CASE CONSTRUCTION. Failure to comply with these rules can result in machine malfunction.*

## Telematics

**NOTE:** *the CASE CONSTRUCTION SiteWatch™ website ([www.casesitewatch.com](http://www.casesitewatch.com)) will not be accessible until the CASE CONSTRUCTION SiteWatch™ subscription for this machine is registered by an authorized CASE CONSTRUCTION dealer. Contact an authorized CASE CONSTRUCTION for details.*

This machine is equipped with a telematics system. This is an asset-monitoring system that combines Internet, cellular, and GPS technologies. A transponder unit is mounted on the equipment that wirelessly communicates with the user interface CASE CONSTRUCTION SiteWatch™ at [www.casesitewatch.com](http://www.casesitewatch.com). Using cellular technology, the transponder can send equipment data, including location, on/off status, usage and production metrics, diagnostic data, movement alarms, and unauthorized usage to the interface. The system will help cut costs and keep accurate records. See the furnished guide for operating your telematics system.

## Manual scope and required training level

### Introduction to this manual

This manual gives information about the use of your CASE CONSTRUCTION machine as intended and under the conditions foreseen by CASE CONSTRUCTION during normal operation, routine service, and maintenance.

This manual does not contain all the information that relates to periodic service, conversions, and repairs that only trained service personnel can perform. Some of these activities may require appropriate facilities, technical skills, and/or tools that CASE CONSTRUCTION does not supply with the machine.

The manual contains the chapters as shown on the Contents pages. See the Index at the end of this manual to locate specific items about your CASE CONSTRUCTION machine.

### Normal operation

Normal operation consists of the use of this machine for the purpose CASE CONSTRUCTION intends by an operator that:

- Is familiar with the machine and any mounted equipment or towed equipment
- Complies with the information on operation and safe practices as specified by CASE CONSTRUCTION in this manual and by the signs on the machine

Normal operation includes:

- Preparation and storage of the machine
- Addition and removal of ballast
- Connection and disconnection of mounted equipment and/or towed equipment
- Adjustment and configuration of the machine and equipment for the specific conditions of the job site, field, and/or crop
- Movement of components into and out of working positions

### Routine service and maintenance

Routine service and maintenance consists of the daily activities necessary to maintain the proper machine function. The operator must:

- Be familiar with the machine characteristics
- Comply with the information on routine service and safe practices as specified by CASE CONSTRUCTION in this manual and by the signs on the machine

Routine service can include:

- Fueling
- Cleaning
- Washing

- Topping up fluid levels
- Greasing
- Replacing consumable items such as light bulbs

### Periodic service, conversions, and repairs

Periodic service consists of activities that are necessary to maintain the expected life of the CASE CONSTRUCTION machine. These activities have defined intervals.

Trained service personnel familiar with the machine characteristics must perform these activities at the defined intervals. Trained service personnel must comply with the information on periodic service and safe practices as partly specified by CASE CONSTRUCTION in this manual and/or other company literature.

Periodic service includes:

- Oil change service for the engine, hydraulic circuits, or transmission
- Periodic exchange of other substances or components as required

Conversion activities rebuild the CASE CONSTRUCTION machine in a configuration that is appropriate for a specific job site, crop, and/or soil conditions (e.g., installation of dual wheels). Conversion activities must be done:

- By trained service personnel familiar with the machine characteristics
- By trained service personnel that comply with the information on conversion as partly specified by CASE CONSTRUCTION in this manual, assembly instructions, and/or other company literature

Repair activities restore proper function to a CASE CONSTRUCTION machine after a failure or degradation of performance. Dismantling activities occur during the scrapping and/or dismantling of the machine.

Trained service personnel familiar with the machine characteristics must perform these activities. Trained service personnel must comply with the information for repair as specified by CASE CONSTRUCTION in the service manual.

### Before you operate

Read this manual before you start the engine or operate this CASE CONSTRUCTION machine. Contact your CASE CONSTRUCTION dealer if:

- You do not understand any information in this manual
- You need more information
- You need assistance

All persons training to operate, or who will operate this CASE CONSTRUCTION machine should be old enough to possess a valid local vehicle operating permit (or meet other applicable local age requirements). These persons must demonstrate the ability to operate and service the CASE CONSTRUCTION machine in a correct and safe manner.

### **Additional documents**

When required, the machine is delivered with an assembly instruction. The assembly instruction shows the packaging depending on the kind of shipment and the related procedure to assemble the received components.

## Product Identification Number (PIN)

Record the machine and part identification numbers, if needed, give these numbers to your dealer when you need parts or information for your machine. Keep a record of these numbers and your manufacturer's statement or origin in a safe place. If the machine is stolen, report the numbers to your local law enforcement agency.

### 1. Product identification number

Your machine identification plate is mounted on left hand-side of the chassis.

Model

---

PIN

---

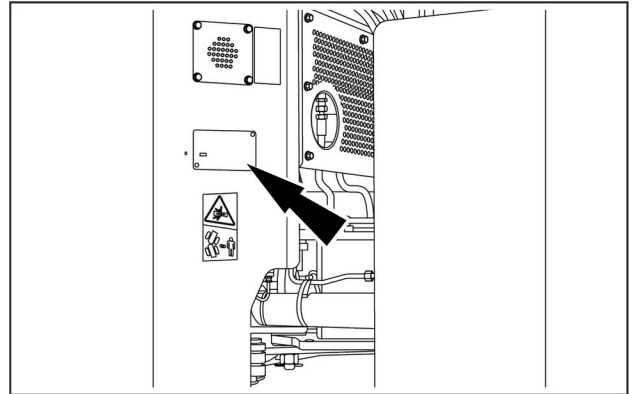

PTIL24COM0982AB 1



PTIL24COM1043AB 2

### 2. Vibration Motor

Model

---

PIN

---

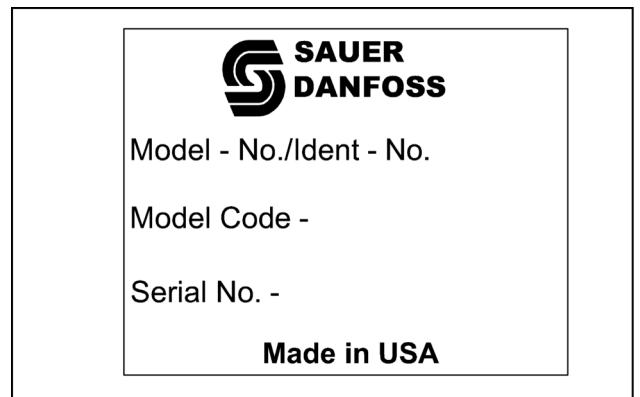

PTIL15COM0175AA 3

**3. Travel Motor**

Model

---

PIN

---

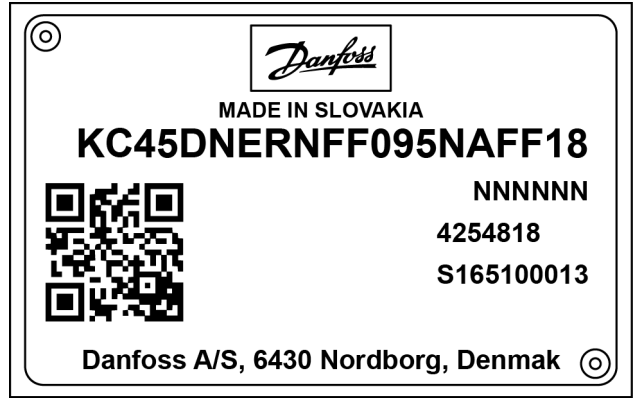

PTIL17COM1042AA 4

**4. Gearbox**

Model

---

PIN

---

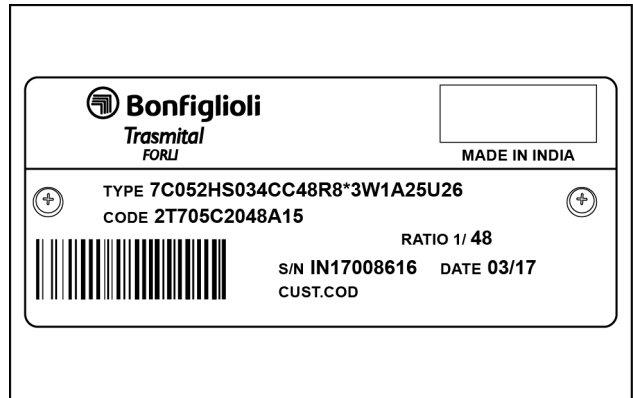

PTIL17COM1041AA 5

**5. Vibration Pump**

Model

---

PIN

---

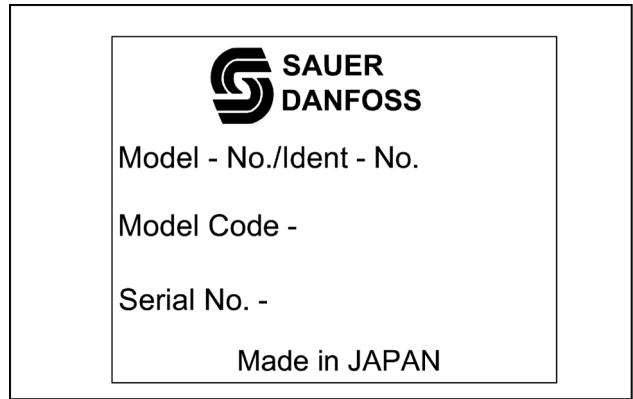

PTIL15COM0178AA 6

**6. Travel Pump**

Model

---

PIN

---

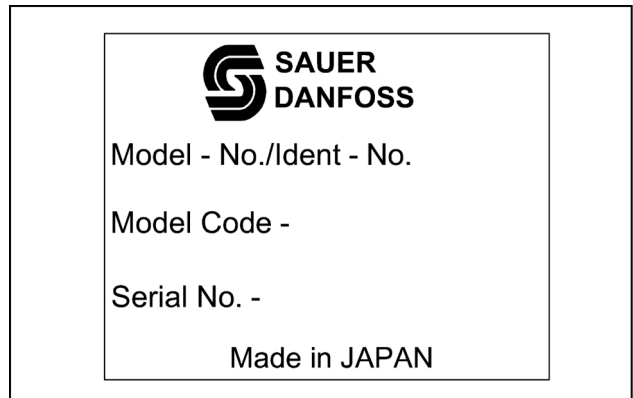

PTIL15COM0179AA 7

**Engine identification plate**

The engine identification plate is located on the oil pan.

PIN

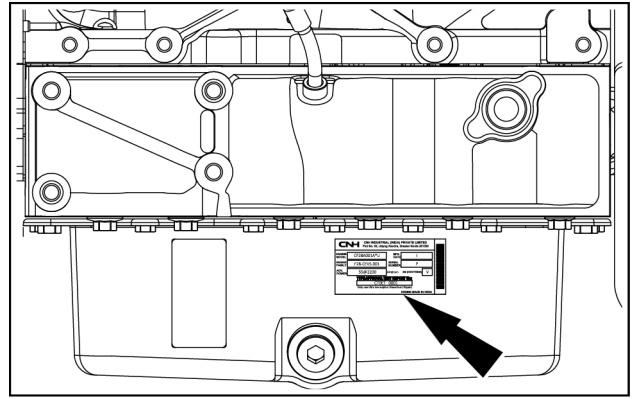

PTIL24COM1127AB 8

<b>CNH INDUSTRIAL (INDIA) PRIVATE LIMITED</b> Plot No. 03, Udyog Kendra, Greater Noida 201306				
ENGINE MODEL	CF28A001A*U	MFG DATE	I	
ENGINE FAMILY	F28-CEV5.001	SERIAL NUMBER	P	
ADV. POWER	55@2200 kW@rpm	BS (CEV/TREM)	V	
TYPE APPROVAL TEST REPORT No: CTOET 0001 Only use Ultra low sulphur Diesel fuel (10ppm) <b>ENGINE MADE IN INDIA</b>				

PTIL24COM1126AB 9

**Roll Over Protective Structure (ROPS)**

Model

PIN

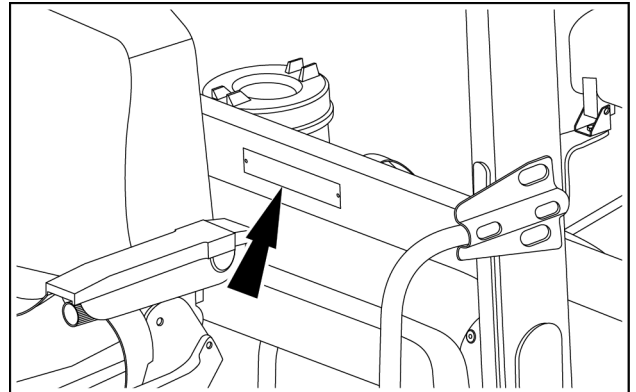

PTIL24COM1125AB 10

Made In India For <b>Case New Holland Construction Equipment (India) Private Limited</b> Plot No. 157, Industrial Area-III, Pitampur - 454774, Madhya Pradesh, India ROPS SERIAL NO.	FOR APPLICATION ON  FOR MAX. MACHINE WEIGHT  APPROVAL NUMBER	TYPE - CERTIFICATION FOR ROLLOVER PROTECTIVE STRUCTURES  PROTECTION AFFORDED BY THE ROPS WILL BE REDUCED IF THE ROPS IS ALTERED, HAS STRUCTURAL DAMAGE, OR HAS BEEN SUBJECT TO UPSET. SEE OPERATOR MANUAL FOR COMPLETE INSTRUCTIONS AND INSPECTION REQUIREMENTS.	MADE IN INDIA
PERFORMANCE STANDARDS: MEASURED IN ACCORDANCE WITH ROPS: ISO 3471 (2008), FOPS: ISO 3449 (2005) (Level)			

PTIL24COM1044AB 11

**NOTE:** It is necessary to quote the details provided on the identification plates of these major components; especially the serial numbers whenever any service / parts assistance is required. The weight of the machine shown on the nameplate is the nominal operating weight.

## Machine orientation

### Operator and seat in the driving position

1. Front view
2. Right-hand side view
3. Left-hand side view
4. Rear view

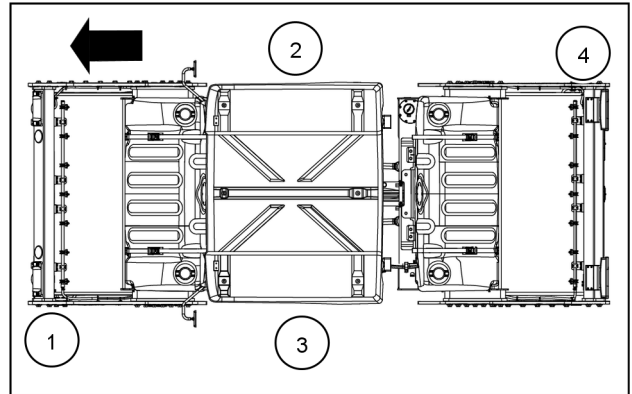

PTIL24COM0973AB 1

# Machine components

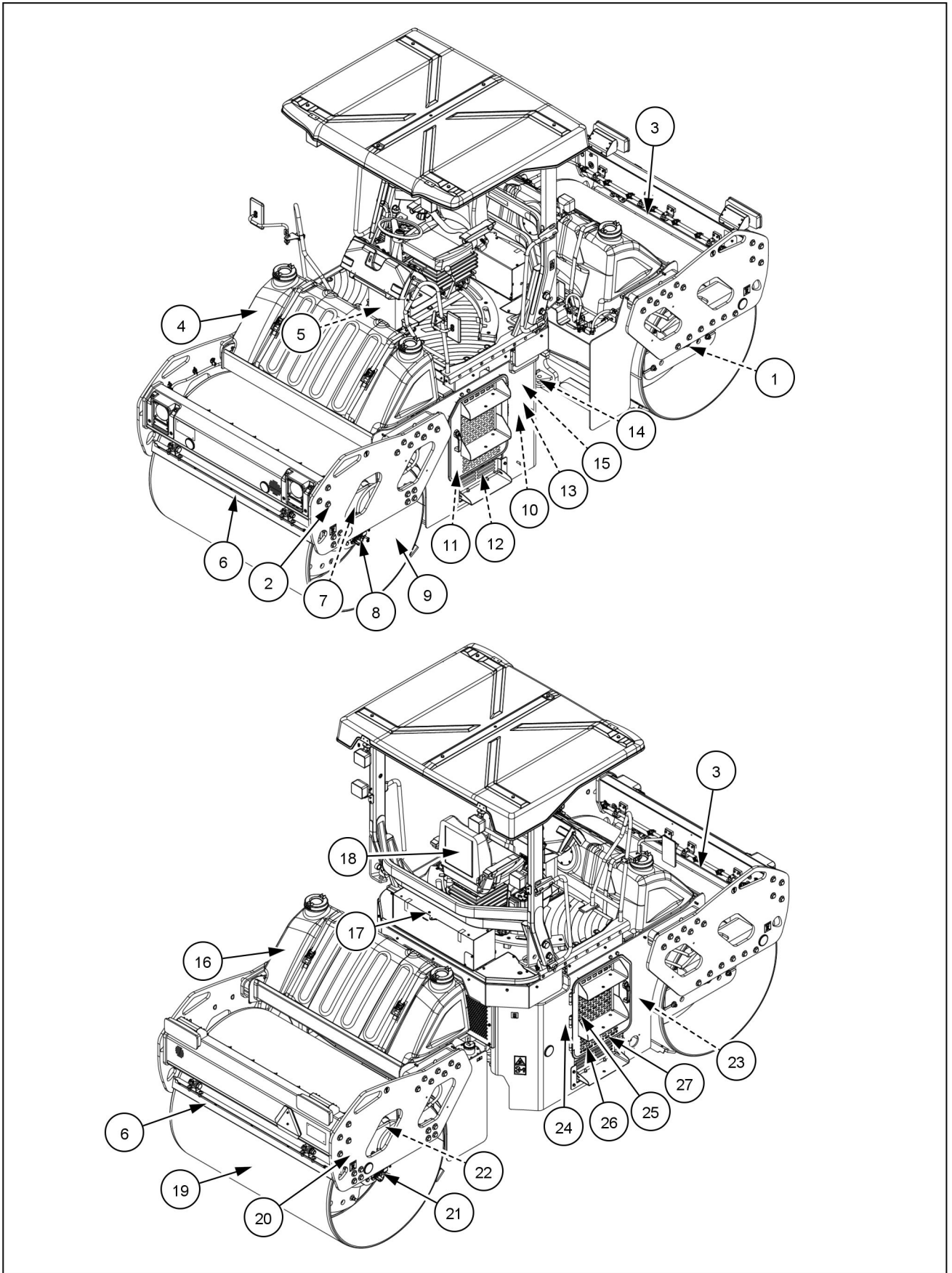

PTIL25COM0210HB 1

## 1 - GENERAL INFORMATION

---

- |     |                      |     |                      |
|-----|----------------------|-----|----------------------|
| 1.  | Vibration motor      | 15. | Fuel filter          |
| 2.  | Front roller frame   | 16. | Rear water tank      |
| 3.  | Sprinkler tube       | 17. | Battery              |
| 4.  | Front water tank     | 18. | Operator's seat      |
| 5.  | Steering unit        | 19. | Rear roller drum     |
| 6.  | Scraper              | 20. | Rear roller frame    |
| 7.  | Front exciter shaft  | 21. | Rear travel motor    |
| 8.  | Front travel motor   | 22. | Rear exciter shaft   |
| 9.  | Front roller drum    | 23. | Hydraulic oil filter |
| 10. | Steering pump        | 24. | Air filter           |
| 11. | Hydraulic oil cooler | 25. | Engine               |
| 12. | Radiator             | 26. | Travel pump          |
| 13. | Steering cylinder    | 27. | Vibration pump       |
| 14. | Articulation Joint   |     |                      |

## 2 - SAFETY INFORMATION

### Safety rules and signal word definitions

#### Personal safety





This is the safety alert symbol. It is used to alert you to potential personal injury hazards. Obey all safety messages that follow this symbol to avoid possible death or injury.

Throughout this manual you will find the signal words DANGER, WARNING, and CAUTION followed by special instructions. These precautions are intended for the personal safety of you and those working with you.

Read and understand all the safety messages in this manual before you operate or service the machine.

 DANGER indicates a hazardous situation that, if not avoided, will result in death or serious injury.

 WARNING indicates a hazardous situation that, if not avoided, could result in death or serious injury.

 CAUTION indicates a hazardous situation that, if not avoided, could result in minor or moderate injury.

**FAILURE TO FOLLOW DANGER, WARNING, AND CAUTION MESSAGES COULD RESULT IN DEATH OR SERIOUS INJURY.**

#### Machine safety

**NOTICE:** Notice indicates a situation that, if not avoided, could result in machine or property damage.

Throughout this manual you will find the signal word Notice followed by special instructions to prevent machine or property damage. The word Notice is used to address practices not related to personal safety.

#### Information

**NOTE:** Note indicates additional information that clarifies steps, procedures, or other information in this manual.

Throughout this manual you will find the word Note followed by additional information about a step, procedure, or other information in the manual. The word Note is not intended to address personal safety or property damage.

## Safety rules

Understand that your safety and the safety of other workers or nearby people is measured by how you service and operate this machine. Know the position and operation of all controls before you try to operate. Check all controls in a safe area before starting your work.

Read this manual completely and make sure you understand the controls. Every equipment has its limitations. Make sure you understand the speed, brakes, steering, stability, and load characteristics of this machine before you start to operate.

Most accidents involving machine operation and maintenance can be avoided by following basic safety rules and precautions. Read and understand all the safety messages in this manual and the safety decals on the machine. Contact your dealer if you have any question.

### Machine application - details

Safety features:

- Electrical circuit protected by relays
- No vibration in high speed mode of travel
- Neutral indicator
- 2 speed indicator
- Battery non-charging indicator
- Low engine oil pressure
- Air filter clog indicator
- Hydraulic oil filter clog indicator
- Parking brake indicator
- Turn indicator
- Hazard lights
- Engine coolant high temperature indicator
- Fuel level gauge
- Engine coolant temperature gauge
- Hour meter
- Emergency stop switch
- Master stop signal
- Operator warning signal
- If parking brake switch is kept ON, the parking brake automatically disengages when machine is not in neutral.

### Safety rules - basic operating

#### **▲ WARNING**

##### **Escaping fluid!**

**Hydraulic fluid or diesel fuel leaking under pressure can penetrate the skin and cause infection or other injury. To prevent personal injury: Relieve all pressure before disconnecting fluid lines or performing work on the hydraulic system. Before applying pressure, make sure all connections are tight and all components are in good condition. Never use your hand to check for suspected leaks under pressure. Use a piece of cardboard or wood for this purpose. If injured by leaking fluid, see your doctor immediately.**

**Failure to comply could result in death or serious injury.**

W0178A

**⚠ WARNING**

**Some components may continue to run down after you disengage drive systems.  
Make sure all drive systems are fully disengaged.  
Failure to comply could result in death or serious injury.**

W0113A

- Always check the operating and the road safety of the machine before starting.
- Always make sure the working area is clear of other persons, domestic animals, tools, etc.
- Before starting the engine, be sure all operating controls are in the neutral or park lock position.
- Start the engine only from the operator's seat. Operate controls only when seated in the operator's seat.
- Always sound horn before starting the machine.
- Never operate the engine in enclosed spaces as harmful exhaust gases may build up.
- Check brakes, steering, and other machine control devices prior to starting operation.
- Before you operate at night, check that all lamps illuminate and are sufficient for same operation.
- This is a one man machine, no riders allowed.
- Tighten all connections before starting the engine or pressurizing the system.
- Do not allow straw, trash, bird nests or flammable material in the machine and remove the same as they can ignite fire on hot surfaces.
- Make sure the fire extinguisher installed on or near the machine.
- Check and make sure to clean all the trash from the machine especially around hot components such as the engine, transmission, exhaust, battery, etc. Do these checks and clean the machine at least once a day, probably at the end of the day. More frequent checks and cleaning of machine may be necessary depending on the operating environment and conditions.
- Check and remove the debris accumulation around moving components such as bearings, pulleys, belts, gears, cleaning fans, etc. More frequent cleaning of the machine may be necessary depending on the operating environment and conditions.
- Check all fuses and relays for correct ratings and validity. Replace the defective or non-complaint parts. Do not bypass/override/tamper any safety systems of the machine.
- Make sure not to weld or flame cut any items that contain flammable material. Clean the items thoroughly with non-flammable solvents before welding or flame-cutting.
- Immediately investigate any unusual smells or odors that may emerge during operation of the machine. Always be aware of such observations and actions thereof.
- Do not smoke or use mobiles while refuelling. It is not advisable to park the machine near a place which poses fire hazard (workshops where welding, grinding, gas cutting etc is underway, bonfires etc).
- While parking the vehicle:
  - Park on a hard, level surface.
  - Put all controls in neutral.
  - Engage the parking brake.
- Before leaving the machine, take suitable precautionary measures to ensure that roller cannot roll away on its own.
- If you wear clothing that is too loose, you can be injured. Always wear clothing that will not catch objects. Extra safety equipment that can be required which includes hard hat, safety shoes, ear protection etc.
- Understand the machine limitations and keep the machine under control.
- Select a gear that will prevent excessive speed when going downhill.

## Safety rules - battery

### **⚠ WARNING**

#### **Hazardous chemicals!**

**Battery electrolyte contains sulfuric acid. Contact with skin and eyes could result in severe irritation and burns. Always wear splash-proof goggles and protective clothing (gloves and aprons). Wash hands after handling.**

**Failure to comply could result in death or serious injury.**

W0006A

Antidote:

- a. External: Rinse well with water, removing any soiled clothing.
  - b. Internal: Avoid vomiting. Drink water to rinse your mouth. Consult a doctor.
  - c. Eyes: Rinse thoroughly with water for **15 min** and get prompt medical attention.
- Follow manufacturers' instruction when storing and handling batteries.
  - Always wear eye protection when working with a battery.
  - Do not create sparks or have open flames when working with a battery.
  - Do not weld, grind or smoke near a battery.
  - When disconnecting the battery terminals, remove the negative cable (-) first and then remove the positive cable (+). When connecting the battery terminals connect the positive (+) cable first and then connect the negative (-) cable.
  - Disconnect the battery (both terminal) before welding on any part of the machine. Failure to do so may cause damage to sensitive electrode components.
  - When using auxiliary batteries or connecting booster cables to start the engine, use the procedure shown in this manual. (Refer to 4-4). Do not short across the terminals.
  - Never lay a metal object across the terminals because a spark, short circuit, explosion, or personal injury may result.
  - Keep batteries out of reach of children and other unauthorized persons.
  - Battery posts terminals, and related accessories contain lead and lead compounds. Wash hands after handling.

## Safety rules - electrical storm safety

- Do not operate machine during an electrical storm.
- Do not make contact with the ground or objects outside the machine.
- If you are on the ground during an electrical storm, stay away from machinery and equipment. Seek shelter in a permanent, protected structure.

## Safety rules - fire or explosion proof prevention

- Leaked or spilled fuel/oil on hot surface or electrical components can cause a fire.
- Engine fuel can cause an explosion or fire. Do not fill the fuel with engine running.
- Sparks from the electrical system or engine exhaust can cause an explosion and fire. Before you operate the machine in an area with flammable dust or vapors, use good ventilation to remove the flammable dust or vapors.

## Safety rules - operator precautions

- Continuous long term contact with hydraulic fluid may cause cancer. Avoid long term contact and wash the skin promptly with soap and water.
- Know and understand the job site traffic flow patterns and obey signalmen, road signs, and flagmen.
- Know and use the hand signals required for particular jobs, and know who has the responsibility for signaling.
- Do not operate the machine if you do not feel well. This can be dangerous for you and for people around you.
- Wear protective equipment when appropriate. Hard hats, protective glasses, protective glasses, shoes, gloves, reflector type vests, respirators and ear protection are examples.

- Do not operate the machine while under the influence of alcohol, drugs, or while otherwise impaired.
- Keep clean of moving parts. Loose clothing, jewelry, watches, long hair, and other loose items can become entangled in moving parts.
- Always check for battery cover properly locked before climbing on the machine.

### **Safety rules - maintenance and repair**

- Perform repair and maintenance work only when the drive is at standstill. Deviation from this rule is allowed when the work cannot be performed without drive.
- Before starting to work on hydraulic lines relieve the same from pressure. Pin-sized and smaller streams of hydraulic oil pressure can penetrate the skin and result in serious injury. If the hydraulic oil under pressure does penetrate the skin, seek medical treatment immediately.
- Refit all the covers, if removed during maintenance work.
- Maintain all hoses and tubes in a good condition. Make sure all connections are tight.
- Make a replacement of any tube or hose that is damaged or thought to be damaged. Do not use your hands to check for leaks. Use a piece of cardboard or wood.
- Use insulated gloves.
- When using hammer to remove and install the pivot pins or separate parts using compressed air or using a grinder, wear eye protection that completely encloses the eyes.
- Before starting to work on the electrical system of the machine, disconnect the battery.
- Lock the articulation joint before carrying out work on rollers with the articulated frame.

### **Safety rules - transportation precautions**

- The machine can be moved within contained construction site by means of propulsion.
- Comply with local laws and regulations.
- Use appropriate lighting as defined by local regulations.
- On public road the machine is to be transported on suitable transport vehicles, In this case the machine must be sufficiently secured against rolling off and sliding on vehicle.
- Travel speed should be such that complete control and machines stability is maintained at all times.

### **Safety rules - safety decals**

The decals are intended for the personal safety of you and those working with you. Please take this manual, walk around your machine and note the content and location of the decals. See **Informational decals**.

It is the owner's/operator's responsibility to keep the decals legible.

When you clean the decals, use only a cloth, water and soap. Do not use solvent, gasoline etc.

## Ecology and the environment

Soil, air, and water quality is important for all industries and life in general. When legislation does not yet rule the treatment of some of the substances that advanced technology requires, sound judgment should govern the use and disposal of products of a chemical and petrochemical nature.

Familiarize yourself with the relative legislation applicable to your country, and make sure that you understand this legislation. Where no legislation exists, obtain information from suppliers of oils, filters, batteries, fuels, anti-freeze, cleaning agents, etc., with regard to the effect of these substances on man and nature and how to safely store, use, and dispose of these substances. Your CASE CONSTRUCTION dealer can also provide assistance.

### Helpful hints

- Avoid the use of cans or other inappropriate pressurized fuel delivery systems to fill tanks. Such delivery systems may cause considerable spillage.
- In general, avoid skin contact with all fuels, oils, acids, solvents, etc. Most of these products contain substances that may be harmful to your health.
- Modern oils contain additives. Do not burn contaminated fuels and or waste oils in ordinary heating systems.
- Avoid spillage when you drain fluids such as used engine coolant mixtures, engine oil, hydraulic fluid, brake fluid, etc. Do not mix drained brake fluids or fuels with lubricants. Store all drained fluids safely until you can dispose of the fluids in a proper way that complies with all local legislation and available resources.
- Do not allow coolant mixtures to get into the soil. Collect and dispose of coolant mixtures properly.
- Do not open the air-conditioning system yourself. It contains gases that should not be released into the atmosphere. Your CASE CONSTRUCTION dealer or air-conditioning specialist has a special extractor for this purpose and can recharge the system properly.
- Repair any leaks or defects in the engine cooling system or hydraulic system immediately.
- Do not increase the pressure in a pressurized circuit as this may lead to a component failure.

### Battery recycling

Batteries and electric accumulators contain several substances that can have a harmful effect on the environment if the batteries are not properly recycled after use.

Improper disposal of batteries can contaminate the soil, groundwater, and waterways.

CASE CONSTRUCTION strongly recommends that you return all used batteries to a CASE CONSTRUCTION dealer, who will dispose of the used batteries or recycle the used batteries properly. In some countries, this is a legal requirement.

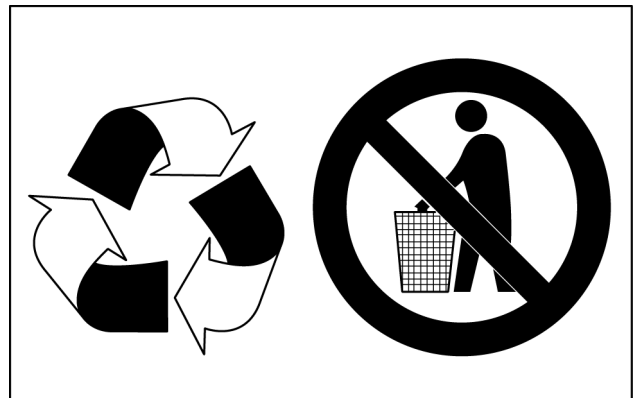

NHIL14GEN0038AA 1

## Hand signals

When operating the machine, never attempt to carry out tasks calling for fine control or working in areas where visibility is poor or impaired without seeking the assistance of a signalman. Make perfectly sure that you and the signalman understand the signals to be used.

The operator must always keep visual contact with the flagman, stop the machine immediately if the contact is lost.

### Start the engine



PDE0002ATBP1 1

### Move away from me

Wave hands back and forth (palms outwards).



PDE0003TBP1 4

### Shut down the engine

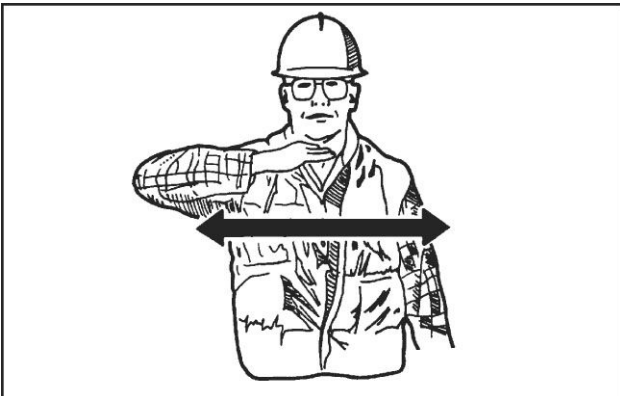

PDE0002TBP1 2

### Go this far

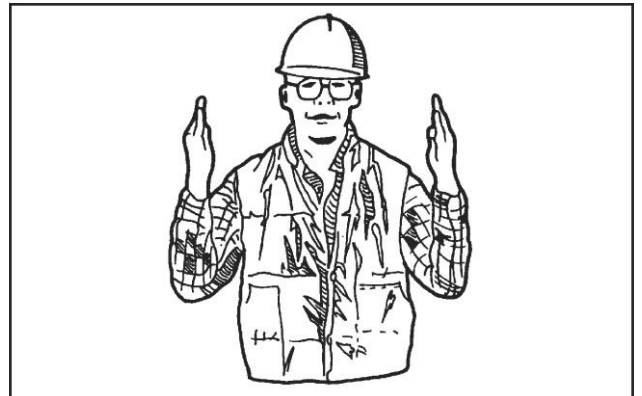

PDE0004ATBP1 5

### Come to me

Wave hands back and forth (palms inwards).



PDE0003ATBP1 3

### All stop and hold



PDE0004TBP1 6

**Stop**

Wave one hand back and forth.

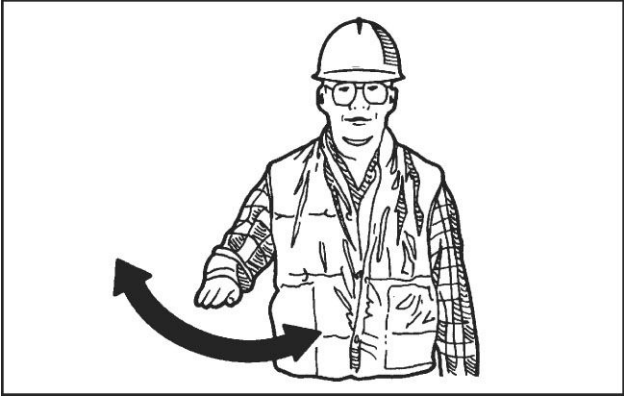

PDE0005ATBP1 7

**Turn machine left (swing load left)**

To stop movement, stop moving hand and clench fist.

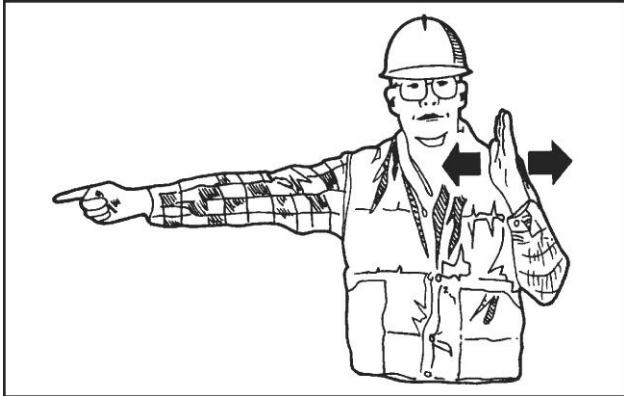

PDE0008ATBP1 9

**Emergency stop**

Wave hands back and forth.

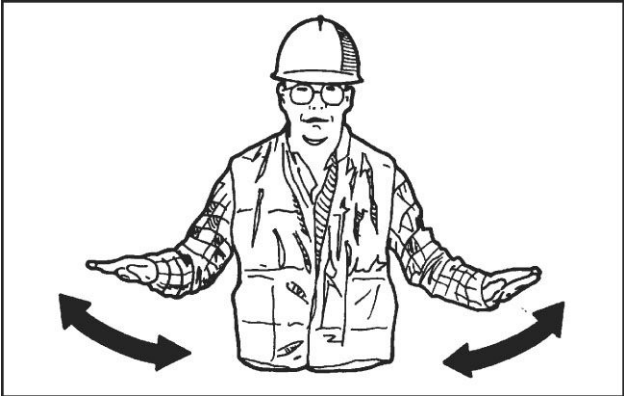

PDE0005TBP1 8

**Turn machine right (swing load right)**

To stop movement, stop moving hand and clench fist.

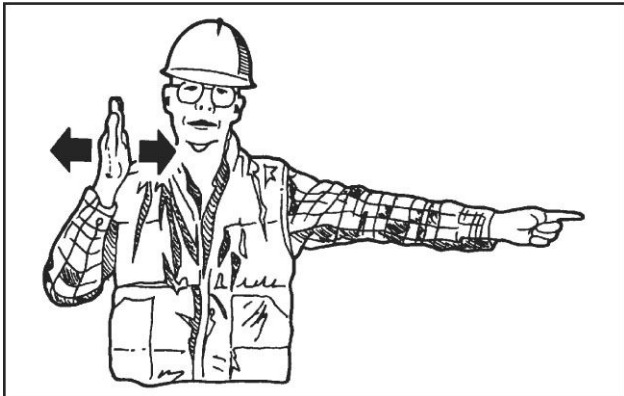

PDE0008TBP1 10

## Safety rules - Utility precautions - Utility precautions

YOU MUST FOLLOW safety precautions when you work near buried utility lines.

During operation, it is likely that you will be working around or near buried utility lines that may include, but are not limited to:

- Electrical power line
- Gas line
- Water line
- Communication line - telephone or cable television
- Sewer line

**NOTE:** Before construction work begins it is your responsibility to be aware of all utility lines in the area of your project and to avoid them.

ALWAYS have all local utility companies mark the location of their lines.

In U.S.A. and Canada call one of many One Call System Director services. If you do not know the local number, call the national number (U.S.A. and Canada only): 1-888-258-0808. This number will direct you to the state or regional utility that assists with excavation activity.

**NOTE:** Check with local authorities for laws, regulations, and/or strict penalties requiring you to locate and avoid existing utilities.

### Call all utility companies before you perform any machine operation

After you locate any buried utility lines, carefully dig a hole to the utility line by hand and/or with automatic vacuum equipment. Verify the location and depth of the line.

Where applicable, know the utility color code.

Electric	Red
Gas, Oil, or Petroleum	Yellow
Communication, Telephone, Television	Orange
Water	Blue
Sewer	Green or Brown
Proposed Excavation	White
Surveying	Pink
Reclaimed Water and Slurry	Purple

Coordinate all excavation activity with the proper authorities and professionals before beginning.

## Safety rules - Fuel handling precautions - Fuel handling precautions

- Do not smoke or permit open flames while fueling or near fueling operations.
- Do not fill the fuel tank completely to the top. Allow room for expansion.
- Clean up spilled fuel immediately and dispose of contaminated material in an environmentally correct manner.
- Tighten the fuel tank cap securely. Should the fuel cap be lost, replace it only with the original manufacturer's approved cap. Use of a non-approved cap without proper venting may result in pressurization of the tank.
- Never use fuel for cleaning purposes.
- Use the correct fuel grade for the operating season.

## **Safety rules - Specific precautions to this machine**

- Always check the operating condition and the road safety of the machine before starting.
- Always make sure the working area is clear of other persons, domestic animals, tools, etc.
- Before starting the engine, be sure all operating controls are in the neutral or park lock position.
- Start the engine only from the operator's seat. Operate controls only when seated in the operator's seat.
- Always sound horn before starting the machine.
- Never operate the engine in enclosed spaces as harmful exhaust gases may build up.
- Check Brakes, steering, and other machine control devices prior to starting operation.
- Before you operate at night, check that all lamps illuminate and are sufficient for same operation.
- This is a one man machine, no riders allowed.
- Tighten all connections before starting the engine or pressurizing the system.
- While parking the vehicle:
  - Park on a hard, level surface.
  - Put all controls in neutral.
  - Engage the parking brake.
- Before leaving the machine, take suitable precautionary measures to ensure that roller cannot roll away on its own.
- If you wear clothing that is too loose, you can be injured. Always wear clothing that will not catch objects. Extra safety equipment that can be required which includes hard hat, safety shoes, ear protection etc.
- Understand the machine limitations and keep the machine under control.
- Operate machine in low speeds when travelling on slope.
- Do not make any unauthorized modifications. Consult an authorized dealer before making any changes, additions, or modifications to this machine.

## Safety signs

### ⚠ WARNING

**Avoid injury!**

**Make sure safety signs are legible. Clean safety signs regularly. Replace all damaged, missing, painted over, or illegible safety signs. See your dealer for replacement safety signs. If a safety sign is on a part that is replaced, make sure the new part has a safety sign.**

**Failure to comply could result in death or serious injury.**

W0168A

### ⚠ WARNING

**Avoid injury!**

**An illegible or missing safety sign can have far-reaching consequences. Inspect safety signs daily. Clean and replace damaged safety signs as necessary.**

**Failure to comply could result in death or serious injury.**

W0167A

The following safety signs are on your machine as a guide for your safety and for the safety of those working with you. Walk around the machine and note the content and the location of all safety signs before you operate your machine.

Keep all safety signs clean and legible. Clean safety signs with a soft cloth, water, and gentle detergent.

**NOTICE:** Do not use solvent, gasoline, or other harsh chemicals. Solvents, gasoline, and other harsh chemicals may damage or remove safety signs.

Replace all safety signs that are damaged, missing, painted over, or illegible. If a safety sign is on a part you or your dealer replaces, make sure that you or your dealer install the safety sign on the new part. See your dealer for replacement safety signs.

Safety signs that display the “Read operator’s manual” symbol direct you to the operator’s manual for further information regarding maintenance, adjustments, or procedures for particular areas of the machine. When a safety sign displays this symbol, consult the appropriate page of the operator’s manual.

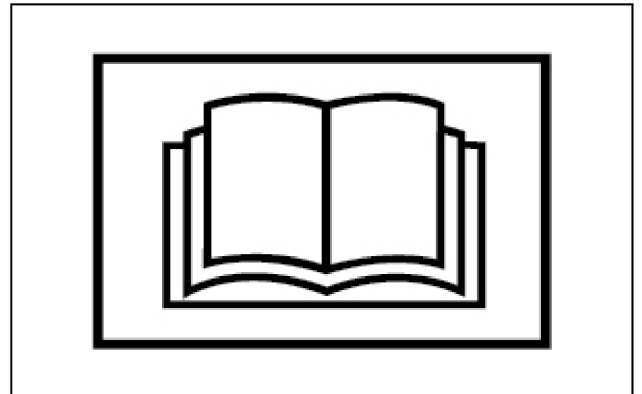

PTIL21COM0115AB 1

Safety signs that display the “Read service manual” symbol direct you to the service manual. If you doubt your ability to perform service operations, contact your dealer.

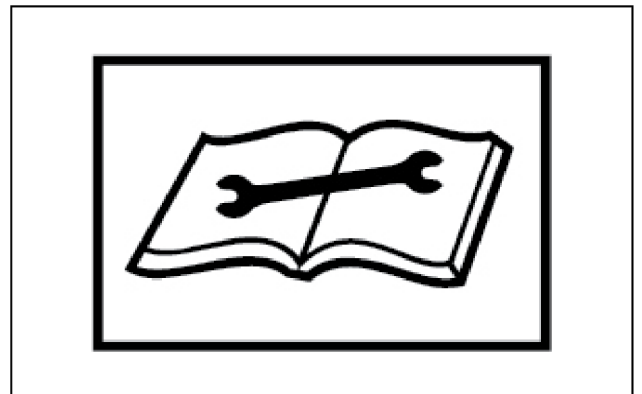

PTIL21COM0116AB 2

**Decals**

The following Decals are placed on your machine as a guide for your safety and for those working with you. Walk around the machine and note the content and location of these Decals before operating your machine.

1- "Crush hazard" decal  
 This decal shows to maintain distance from the frame.  
 Quantity :2  
 323695A1

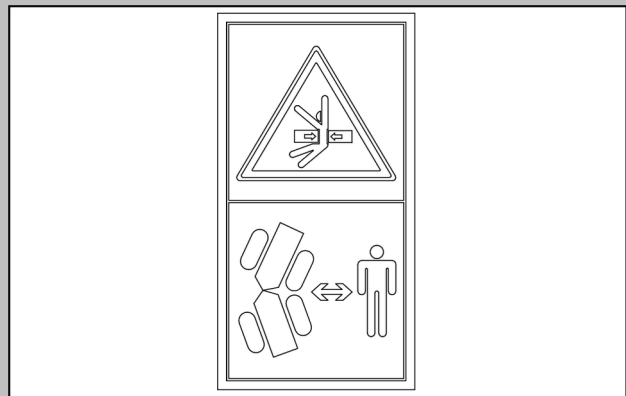

PTIL21COM0430AB 3

This decal is located on both sides of the front chassis near articulation area.

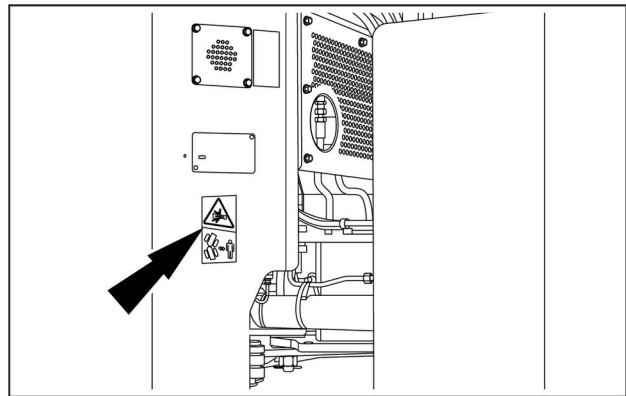

PTIL24COM0982AB 4

2- "Ignition key position" decal  
 This decal shows to ignition state of the machine.  
 Quantity :1  
 47531139

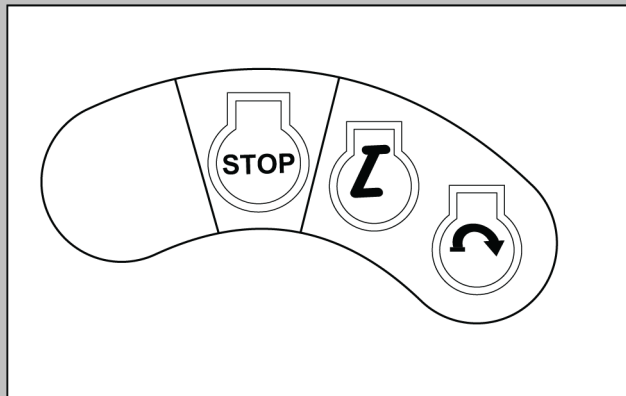

47531139 5

This decal is located on the Right-hand side front console assembly.

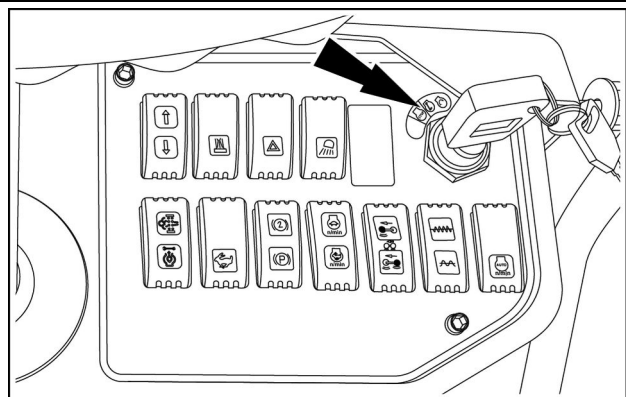

PTIL24COM1133AB 6

2 - SAFETY INFORMATION

3- "FNR" decal  
This decal shows position of FNR lever.  
Quantity :1  
48049795

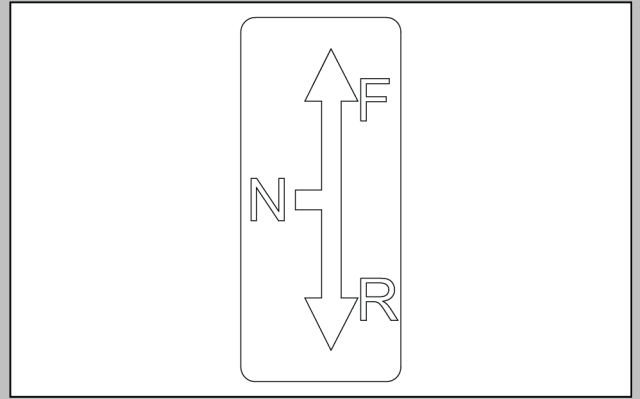

PTIL25COM0190AB 7

This decal is located on the right-hand side control system near the operator seat.

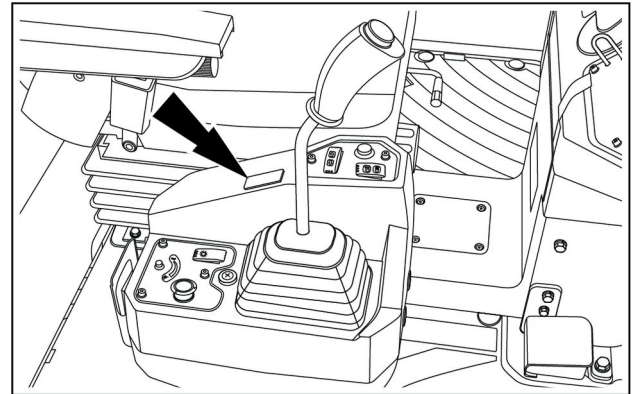

PTIL24COM1188AB 8

4- "General hazard" decal  
This decal shows general safety measures.  
Quantity :1  
84270888

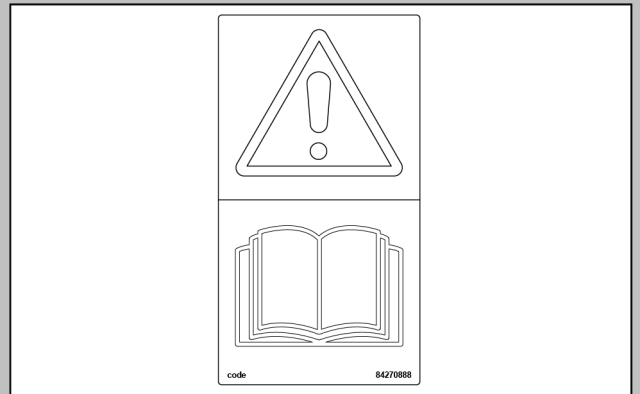

84270888 D 9

This decal is located on the left side of the canopy.

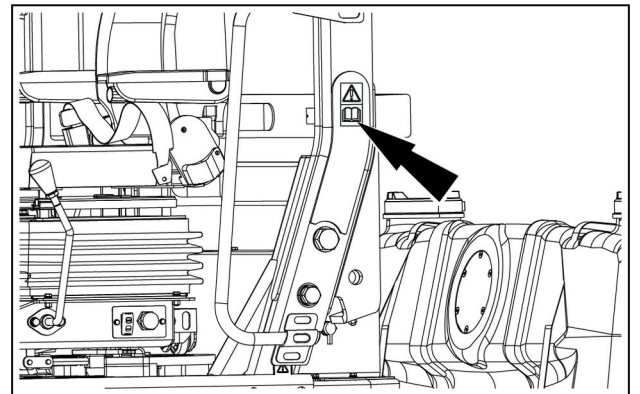

PTIL25COM0214AB 10

5- "Tie-down" decal  
Use these points to tie the machine during transport on a trailer.  
Failure to comply with this recommendation may result in damage, serious injuries, or death.  
Quantity :4  
84315529

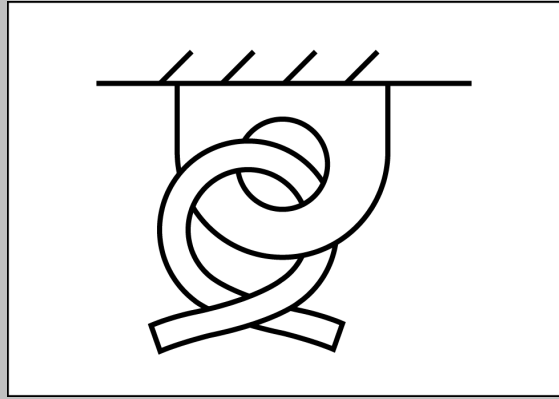

84315529A 11

This decal is located on front and rear chassis.

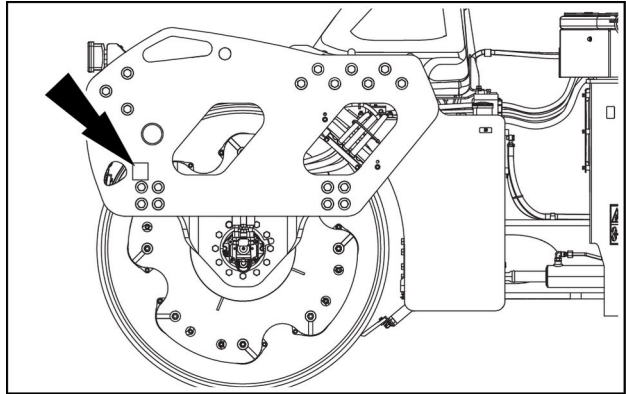

PTIL24COM0978AB 12

6- "Low sulfur diesel fuel" decal  
Quantity :1  
84319035

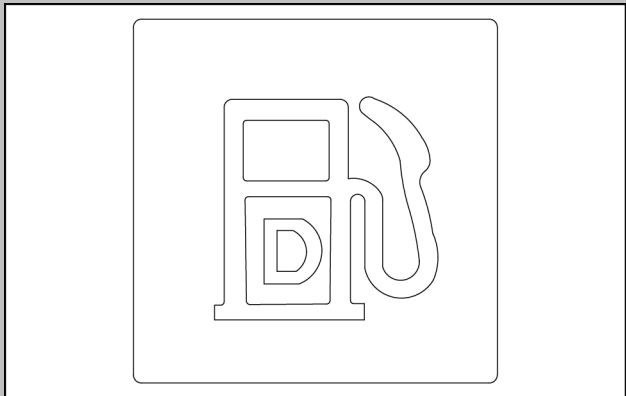

84319035B 13

This decal is located on right-hand side of the rear chassis.

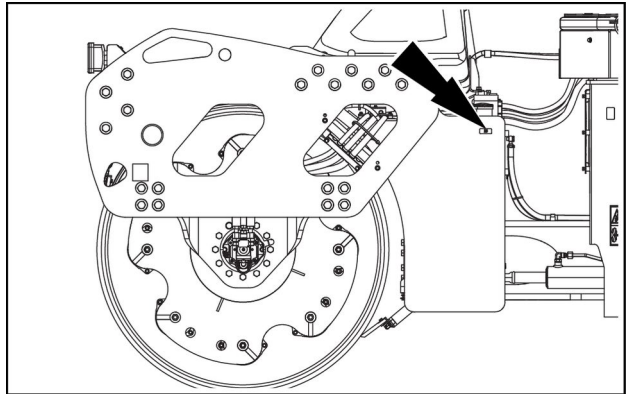

PTIL24COM0978AB 14

## 2 - SAFETY INFORMATION

7- "Hydraulic tank identification " decal  
At operating temperature, hydraulic fluid can cause burns in case of contact with the skin.  
Quantity :1  
85804341

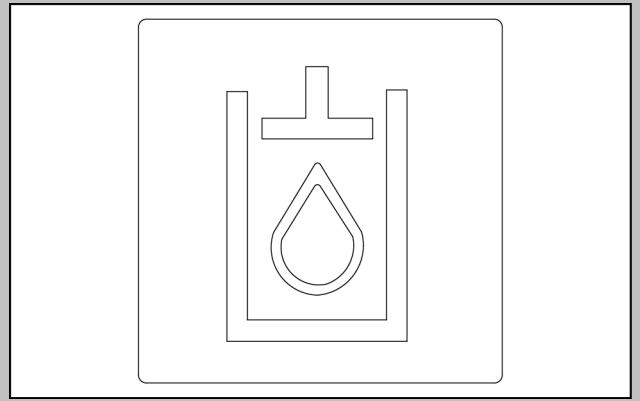

85804341 15

This decal is located on right side of the frame.

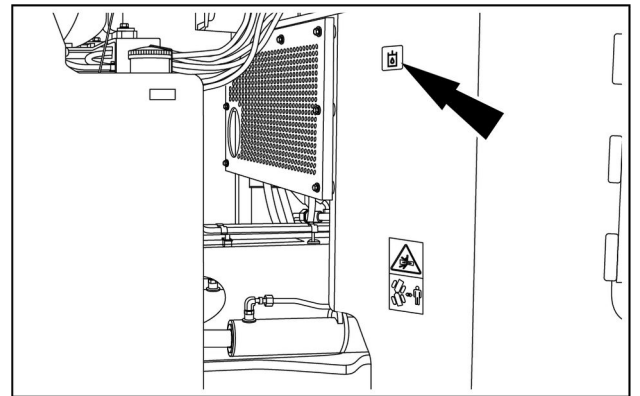

PTIL24COM0980AB 16

8- "Sprinkler " decal  
This decal shows the information on the water spraying outward.  
Quantity :1  
48065443

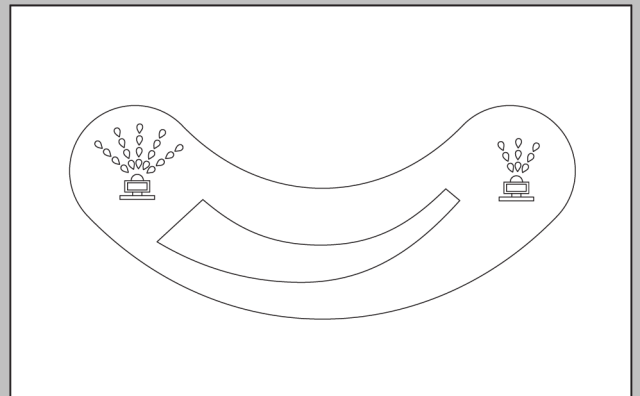

PTIL24COM0986AB 17

This decal is located on the right-hand side control system near the operator seat.

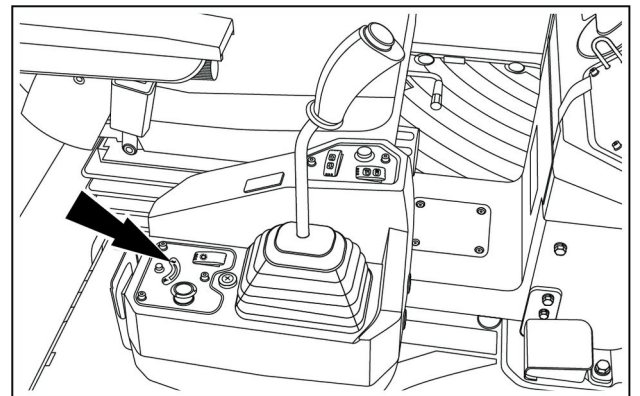

PTIL24COM1188AB 18

9- "Water tank" identification decal  
This decal shows the information on the water level in the machine.  
Quantity :4  
90401371

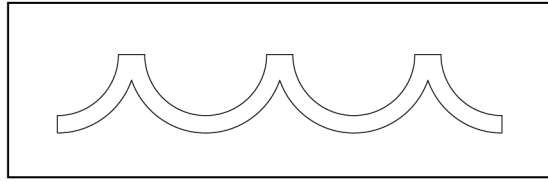

PTIL21COM0189AB 19

This decal is located on the cap of the water tank.

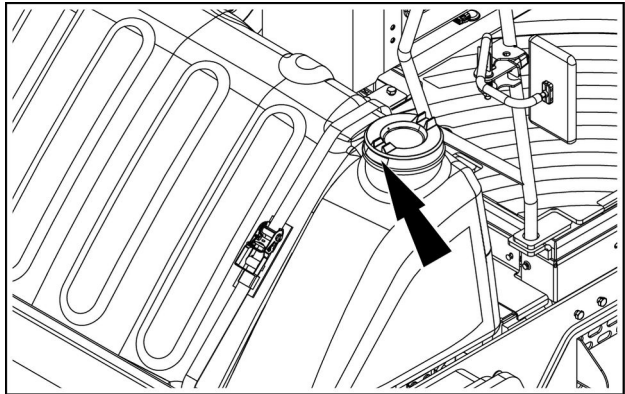

PTIL24COM0985AB 20

10- "Do not pressure wash fan " decal  
Quantity :2  
51512906

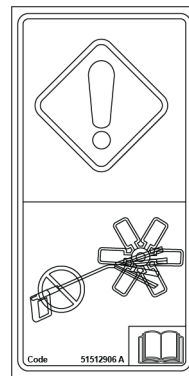

51512906 A 21

This decal is located on the right-hand side and left-hand side of the radiator.

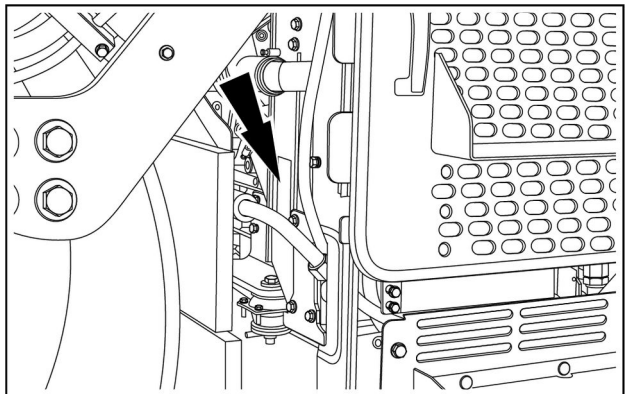

PTIL24COM0976AB 22

2 - SAFETY INFORMATION

11- "Hot liquid" decal  
 This decal shows the information do not open the cap when liquid is hot.  
 Quantity :1  
 87494551

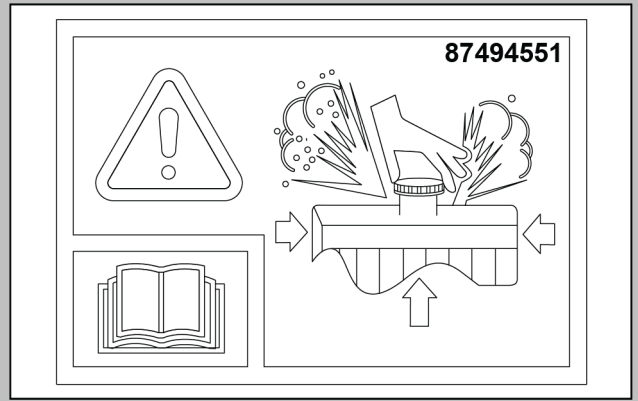

87494551 23

This decal is located on cooling pack.

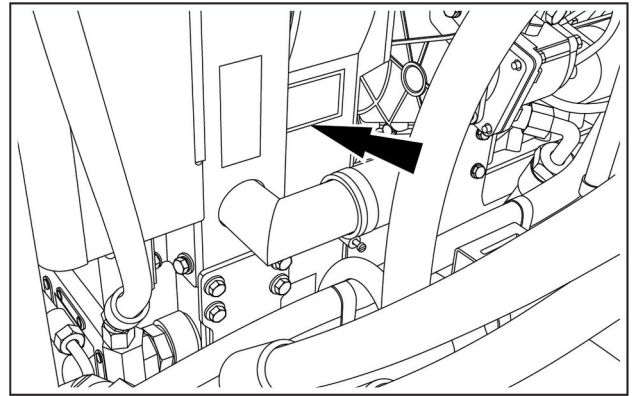

PTIL24COM0981AB 24

12- "OAT COOLANT- ACTIFULL OT" decal  
 This decal shows the information about the coolant to be used.  
 Quantity :1  
 47757330

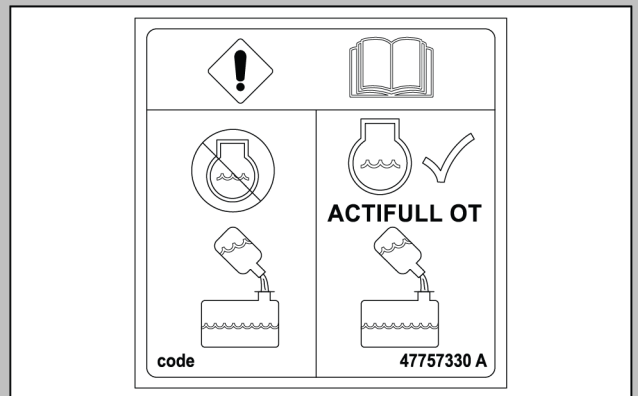

47757330\_A 25

This decal is located on cooling pack

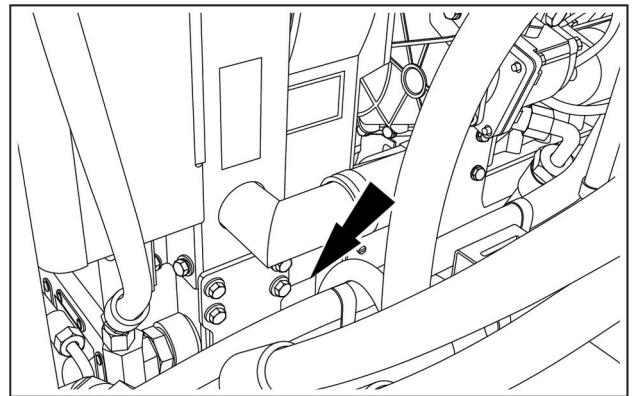

PTIL24COM0981AB 26

13- "Fan hazard" decal

This decal shows the information on the fan hazard the machine.

Quantity :1  
332511A1

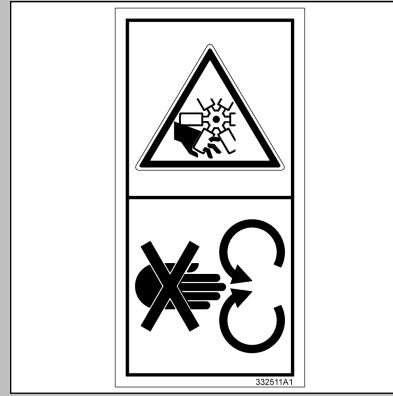

332511A1 27

This decal is located on left side of the chassis.

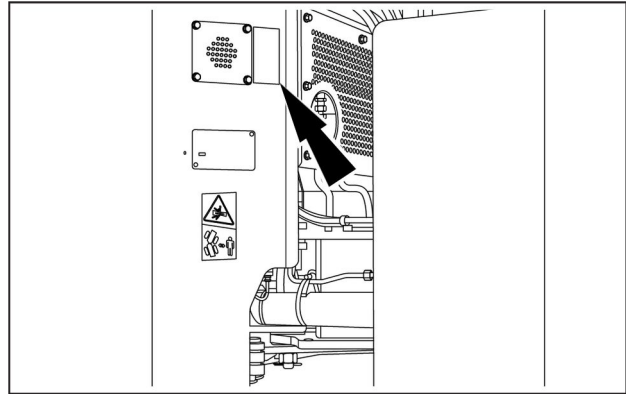

PTIL24COM0982AB 28

14- "Lift points" decal

Use these points to tie the machine during lifting on a trailer.

Failure to comply with this recommendation may result in damage, serious injuries, or death.

Quantity :4  
85804336

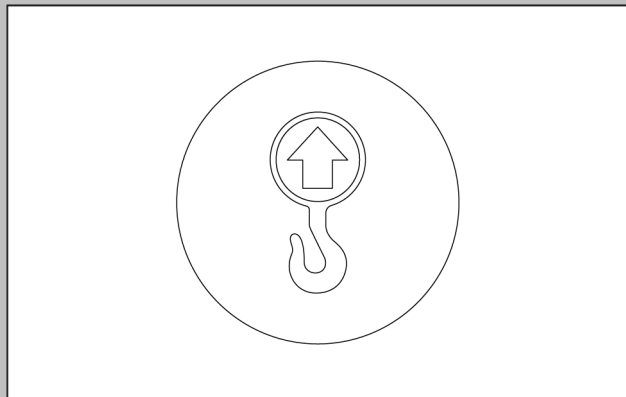

PTIL24COM0990AB 29

This decal is located on all the four side plates.

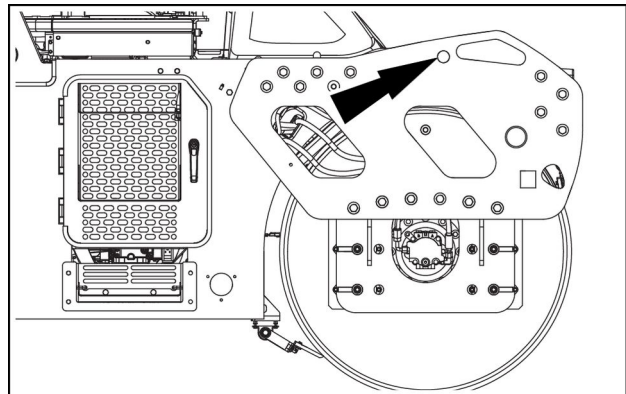

PTIL24COM0979AB 30

2 - SAFETY INFORMATION

15- "High coolant level" decal  
Do not fill the coolant above the decal level.  
Quantity :1  
51681805

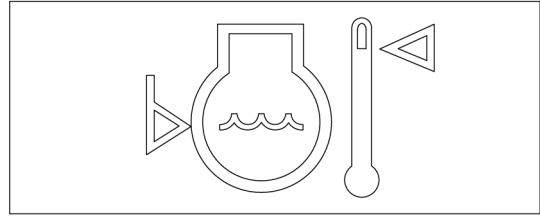

PTIL24COM0988AB 31

This decal is located on the top right side of the Deaeration tank.

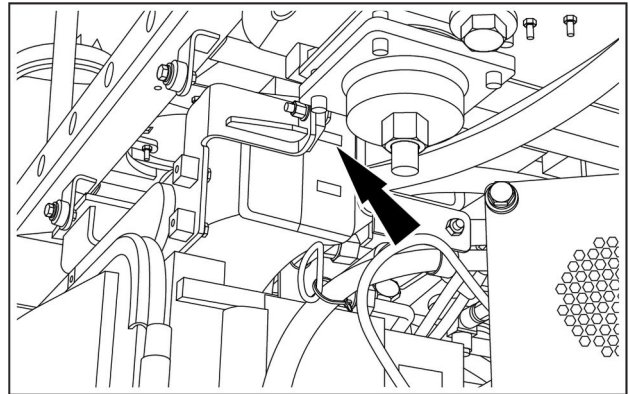

PTIL24COM0977AB 32

16- "Low coolant level" decal  
Add coolant when level is below the decal.  
Quantity :1  
51684243

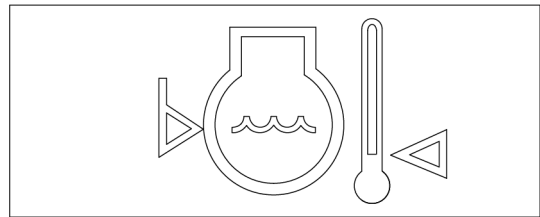

PTIL24COM0989AB 33

This decal is located on the low right side of the Deaeration tank.

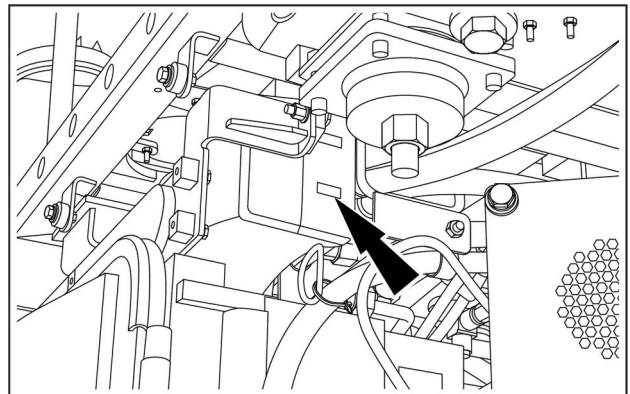

PTIL24COM0977AB 34

17- "Warning-fuel pressure" decal  
This decal shows the warning of the pressurized fuel.  
Quantity :1  
87581010



PTIL24COM0190AB 35

This decal is located on left side of the chassis.

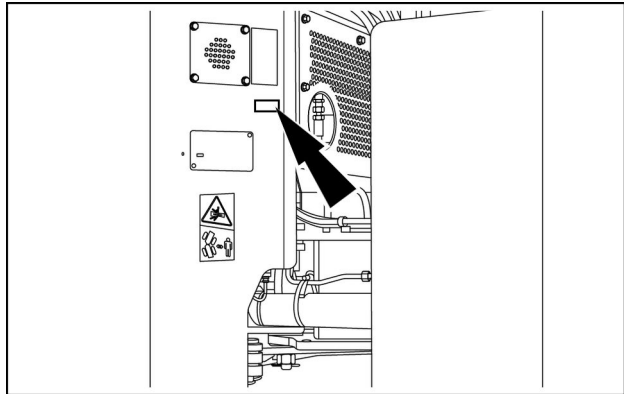

PTIL24COM0982AB 36

## General safety rules

1. Make sure to arrest all fuel leaks. Any fuel or oil spilled on hot surface or electrical components may cause fire accidents. Make sure that the machine is sealed from leakage.
2. Do not allow straw, trash, bird nests or flammable material in the machine and remove the same as they can ignite fire on hot surfaces.
3. Make sure the fire extinguisher installed on or near the machine. If already equipped, the fire extinguisher is maintained and serviced according to the manufacturer's instructions.
4. Check and make sure to clean all the trash from the machine especially around hot components such as the engine, transmission, exhaust, battery, etc. Do these checks and clean the machine at least once a day, probably at the end of the day. More frequent checks and cleaning of machine may be necessary depending on the operating environment and conditions.
5. Inspect the electrical system for loose connections and frayed insulation. Repair or replace the loose or damaged parts.
6. Check and remove the debris accumulation around moving components such as bearings, pulleys, belts, gears, cleaning fans, etc. More frequent cleaning of the machine may be necessary depending on the operating environment and conditions.
7. Check all Fuses, Relay, and MCB's for correct ratings and validity. Replace the defective or non-complaint parts. Do not to bypass/override/tamper any safety systems of the machine.
8. Check and remove any oily rags or other flammable material on the machine. Do not to store such material around or on the machine.
9. Make sure that do not weld or flame cut any items that contain flammable material. Clean the items thoroughly with non-flammable solvents before welding or flame-cutting.
10. Immediately investigate any unusual smells or odors that may emerge during operation of the machine. Always aware of such observations and actions thereof.
11. Make sure that the machine is serviced only by authorized CASE CONSTRUCTION dealer service team and not by any external parties.
12. Check and remove any non-recommended devices that are fitted on the machine. Do not to use any devices that are not a standard fitment by the company.
13. The personnel to make sure that they do not smoke or use mobiles while refuelling. It is not advisable to park the machine near a place which poses fire hazard (Workshops where welding, grinding, gas cutting etc is underway, bonfires etc).
14. Note and avoid all hazards and obstructions such as ditches, underground lines, trees, cliffs, overhead electrical wires, or, areas where there is danger of the landslide.

**NOTICE:** Any damage to the machine due to non-adherence of the above guidelines and instructions may lead the warranty void for the machine.

**Safety Precautions - Lines of utility facilities**

**NOTICE:** Safety precautions must be taken when working near buried or overhead utility lines, such as electrical power cables, communication cables (phone, Internet, TV), gas pipes, water pipes, sewer pipes, or others.

**NOTICE:** Before you begin any machine operation, it is your responsibility to be aware of all possible utility lines in the area of your project and to avoid them. Ask local authorities and utility companies for the demarcation and location of their underground lines.

**NOTICE:** Check with local authorities for laws, regulations, and/or strict penalties that require you to locate and avoid existing utility lines. Keep the minimum distance from underground utility lines that is required by law.

**NOTE:** After you locate any buried utility lines, carefully dig a hole to the utility line to verify the location and depth of the line.

**NOTE:** Assess in advance the location in which the machine will be operating. Make sure that the operating site is large enough to move and operate the machine.

**Call all local utility companies before you perform any machine operation**

Know the utility color code:	
Electric	Red
Gas, oil, or petroleum	Yellow
Communication, telephone, television	Orange
Water	Blue
Sewer	Green / Brown
Proposed excavation	White
Surveying	Pink
Reclaimed water and slurry	Purple

After locating any buried utility lines, carefully dig a hole by hand and/or automatic vacuum equipment to the utility line to verify the location and depth of the line.

**Special precautions with electrical power lines**

**NOTICE:** Contact with suspended power lines can cause burns or death by electrocution. Make sure that there is enough space between the machine and suspended power lines.

Before you drive or operate the machine in areas with high-voltage lines and cables, or power stations, check the following procedures:

- You must have the power disconnected or keep a safe working distance from any power lines, cables, or power stations.
- Keep all parts of machine a safety distance away from the power source. you must also know any federal, state / provincial, or local safety codes or regulation that apply to the job site.
- Pay attention to overhead high voltage lines and hanging obstacles.
- Retract raised or extended implements, if necessary.
- Remove or lower radio antennas or other accessories.
- Check and make sure to comply with any local regulations that may be applicable.
- Wet ground will expand the area that could cause any person on it to be affected by electric shock.
- Keep all people and employees away from the work area.

## 2 - SAFETY INFORMATION

---

- Serious injury or death can occur if you do not keep the machine or accessories a safe distance from power lines. High voltage lines require a significant distance to ensure safe operation of the machine (see table below).

<b>Voltage (V)</b>	<b>Safety distance</b>
<b>50000 V or less</b>	<b>3.0 m (9.8 ft)</b>
<b>50000 – 200000 V</b>	<b>4.5 m (14.8 ft)</b>
<b>200000 – 350000 V</b>	<b>5.0 m (16.4 ft)</b>
<b>350000 – 500000 V</b>	<b>7.5 m (24.6 ft)</b>
<b>500000 – 750000 V</b>	<b>10.5 m (34.4 ft)</b>
<b>750000 V or more</b>	<b>13.5 m (44.3 ft)</b>

If any part of the machine touches the high voltage power lines:

- Stop the machine movement immediately.
- Engage the parking brake, stop the engine and remove the key from the ignition switch.
- Check if you can safely leave the cab or your actual position without contact with electrical wires. If not, stay in your position and call for help.
- If you can leave your position without touching electrical lines, jump clear of the machine, making sure you do not make contact with the ground and the machine at the same time.
- Do not allow anyone to touch the machine until the electrical power has been shut off to the power lines.
- If you can break contact, reverse the operation that caused contact with the high voltage power, and move the machine away from the danger area. If you cannot break contact stay in the machine until the utility company de-energizes the line and tells you that the power is off.
- If you have extreme conditions, such as fire, etc., and you are forced to leave the machine, jump as far from the machine as possible with your feet together and do not touch the ground with your hands.



## 3 - CONTROLS AND INSTRUMENTS

### Access to operator's platform

### Warnings and preliminary checking

- The machine must be used by authorized personnel only.
- Make different idle operations assisted by specialized staff.
- All control levers must be handled delicately and gradually.
- All controls must be activated from driver seat only.
- If it's necessary to start the engine in a closed space, be sure that there is a proper system for lethal substances expulsion.
- Before starting the machine be sure that nobody is working near the machine.
- Before getting on the machine, always walk around to check it.
- Use warning horn.
- If some repairs have been made between the last use and the next one, be sure that all fixing elements have been accurately remounted and that all necessary adjustments have been made.

### Access to operator's platform

#### Machine access

**⚠ DANGER**

**Fall hazard!**

**Regularly inspect the access system and all non-slip surfaces (if equipped). Make sure that the access system and non-slip surfaces (if equipped) are free from damage.**

**Failure to comply will result in death or serious injury.**

D0222A

**NOTICE:** Do not use the steering wheel or other controls or accessories as hand holds when entering or exiting the operator's platform.

#### Access to operator's platform

Use the steps (1) and grab handles (2) when entering or leaving the operator's compartment.

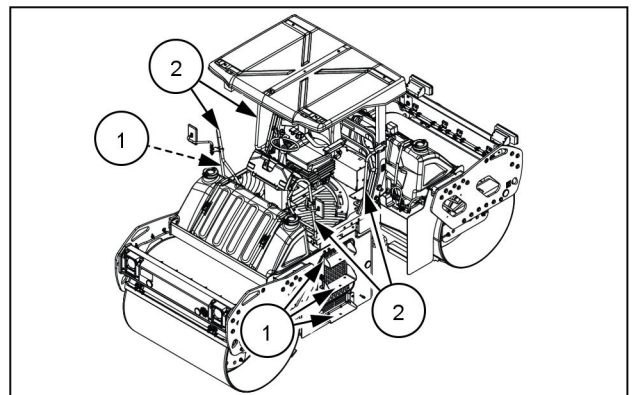

PTIL25COM0211AB 1

## Operator's seat

To operate the machine correctly with maximum efficiency and comfort, check that the operator's seat and its adjustment controls are in good condition and then adjust the seat to suit the operator's height.

**NOTE:** Before using the controls, make sure that the seat is adjusted and positioned correctly.

**NOTICE:** Always fasten your seat belt before starting the engine. The seat belt will protect you efficiently if you attach it correctly and if you always wear it. The seat belt must not be too loose. It must not be twisted or caught in the seat.



PTIL12TLB0047AB 1

## Seat Adjustment

Adjustment may be made to suit the operator's height/weight. Turn the control (1) to obtain the desired height.

## Seat fore-and-aft adjustment

Hold the lever (2) in raised position, slide the seat until the desired position is reached and then release the lever.

## Seat back angle adjustment

To adjust the seat back angle push and hold the lever (3) down and move the seat back to obtain the desired position and then release the lever.

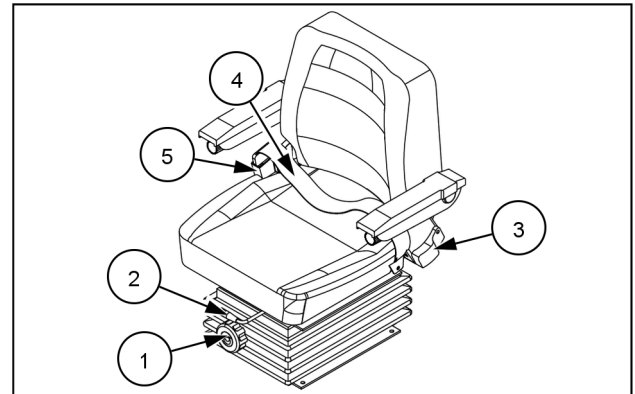

PTIL24COM0592AB 2

## Seat belt

### ⚠ WARNING

Equipment failure could cause accident or injury!

Always fasten the seat belt securely before you operate the machine. Inspect seat belt parts for wear and damage. Replace any and all worn or damaged parts of the seat belt prior to operation.

Failure to comply could result in death or serious injury.

W0046C

- Sit comfortably on the operator's seat.
- Pull out a long section of belt (4).
- Engage the belt in the buckle (5).

**NOTE:** If the section of belt pulled out is not long enough, release it, so it rolls up and then pull it out again. To release the seat belt press down the releasing lever of the buckle.

**NOTICE:** The seat belt must be kept clean. Use only soap and water to clean the belt, do not use bleach or dyes.

- Seat rotation lever **(6)**.
- Water pump controller by pass switch **(7)** - To be used when Pump Control unit is malfunctioning and needs to be bypassed.
- Onboard diagnostic connector **(8)** - Used to connect electronic service tool for checking error code and flashing VCM & ECU software.

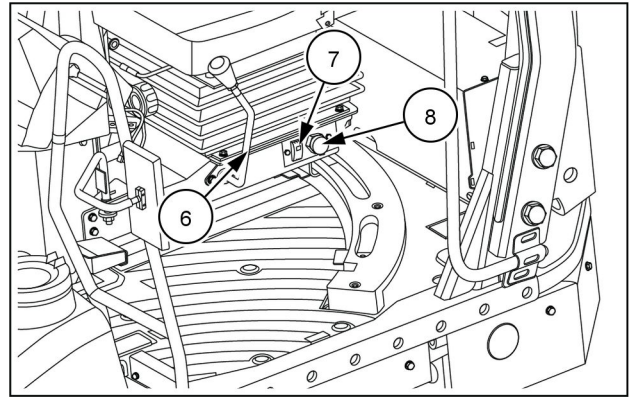

PTIL24COM1189AB 3

- Seat rotation mounting plate **(9)**.

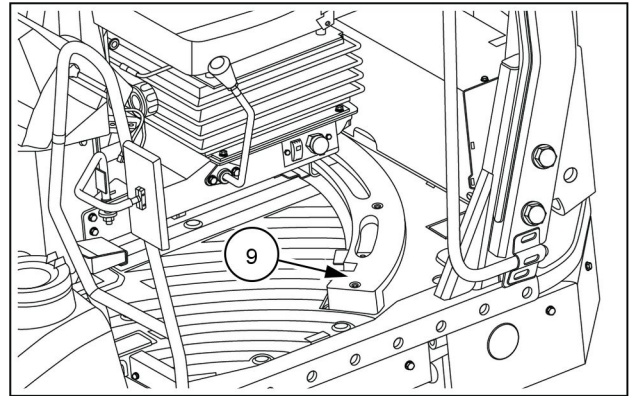

PTIL24COM1189AB 4

## Forward controls

### Forward controls

#### Forward-Neutral-Reverse (FNR) lever

The FNR lever (1) to move the machine.

F - Move forward

N - Neutral or Stop

R - Move Reverse

To move the FNR lever (1) forward, move it forward to the F position. Use the same process to move the lever in the reverse direction

#### Vibration cut-off switch

Press the vibration cut-off switch (2) to stop the drum vibration.

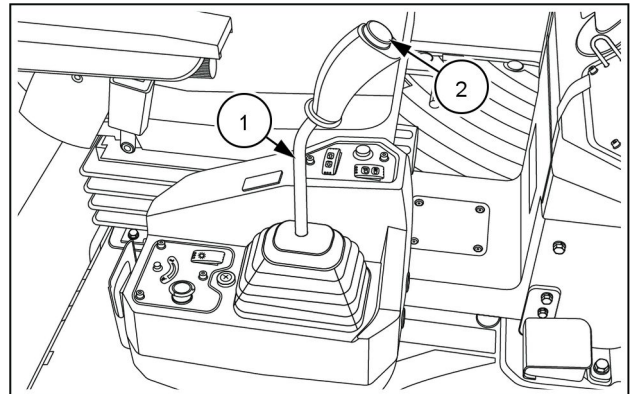

PTIL24COM1188AB 1

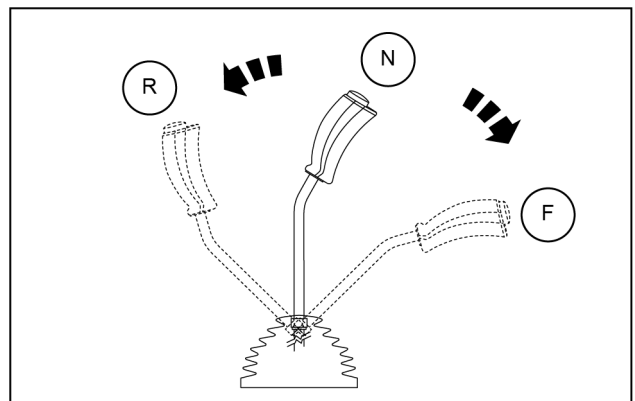

PTIL25COM0194AB 2

## Vandalism protection cover

### Protect against vandalism

Always fold the vandalism cover back before you start the machine.

The vandalism protection cover protects the instruments from:

- The effects of weather
- Vandalism
- Alterations by third parties

Install a padlock to secure the instrument panel from unauthorized access by third parties. There is a loop provided for this purpose.

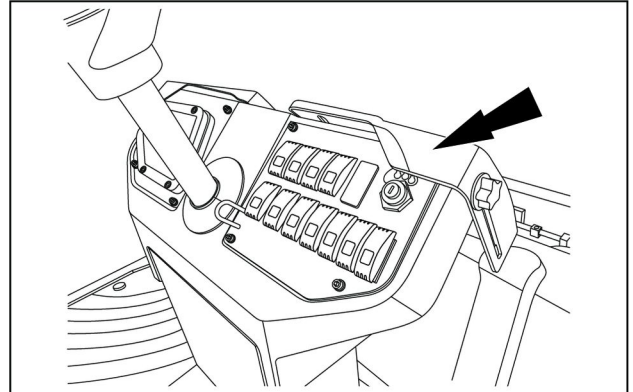

PTIL25COM0195AB 1

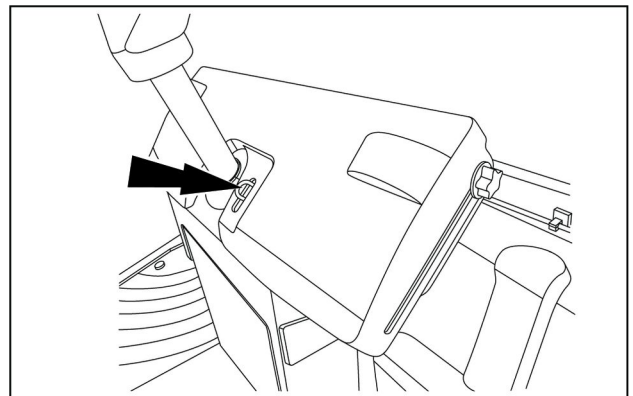

PTIL25COM0196AB 2

## Control panel switches

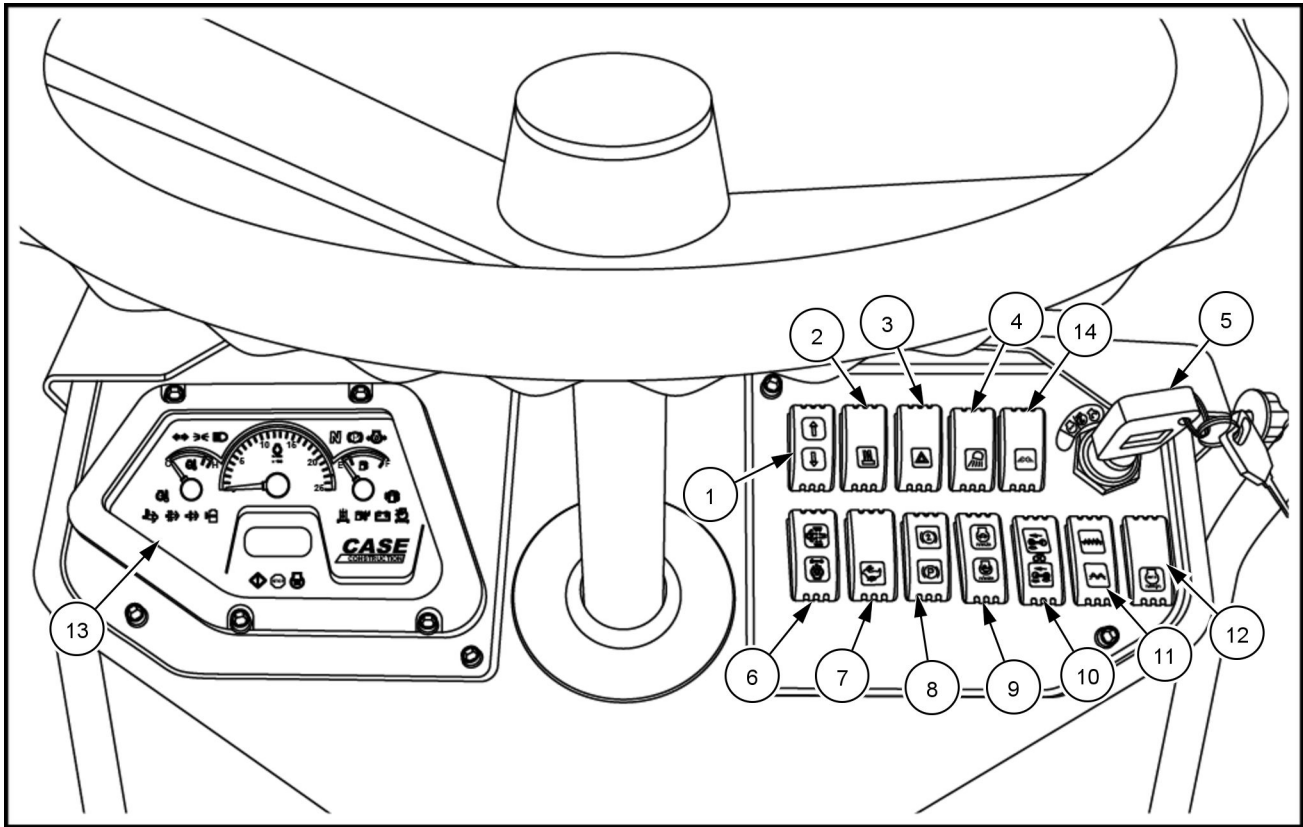

PTIL25COM0257FB 1

1.	Error code view toggle switch	8.	Parking and secondary brake switch
2.	Water sprinkler switch	9.	Throttle switch
3.	Hazard switch	10.	Vibration drum selection switch
4.	Rear work lamp switch	11.	Frequency selector switch
5.	Ignition switch	12.	Auto idle switch
6.	DPF Regeneration/ Engine oil reset switch	13.	Instrument cluster
7.	High speed switch	14.	Side and front work light (optional feature)

### 1. Error code view toggle switch

Press the error code view toggle switch to show the error codes.

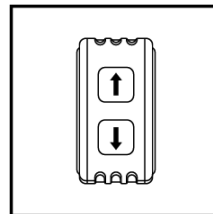

### 2. Water sprinkler switch

Press the water pump switch to turn ON the water sprinkler system.

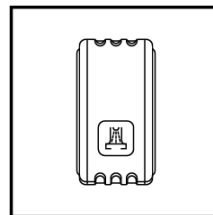

### 3. Hazard switch

Press the hazard switch to turn ON the left and right indicator blinks. During parking the machine on highway in night time this indicator should be put ON.

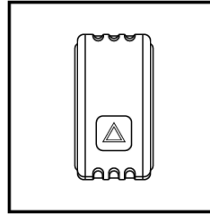

### 4. Rear work lamp switch

Rear work lamp switch will turn ON the rear work lamps.

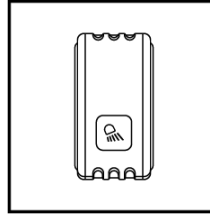

### 5. Ignition switch

The ignition switch on the machine can be operated only with the key provided with the machine. To connect the battery to the ignition circuit, insert the key and turn clockwise. Battery non-charging indicator and low lube oil pressure indicator will start glowing. Now the engine can be started. This switch has a feature to not allow cranking if engine has already been cranked once and key has not been brought to zero position.

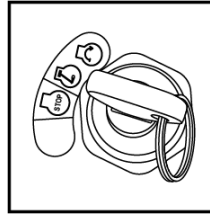

### 6. DPF Regeneration/ Engine oil reset switch

A - Activate manual regeneration of the DPF by pressing the button continuously for **3 s** when there is a request from the ECU to the cluster.

B - To reset the oil change interval, turn the ignition switch to ON, press park brake switch, then press oil change interval reset button for **3 s**.

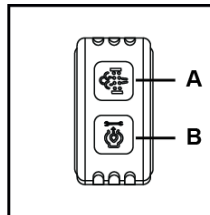

### 7. High speed switch

Press the lower end of the switch to select high travel speed. Press the upper end of the switch to select working speed.

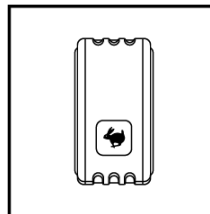

## 8. Parking and secondary brake switch

It is a three position switch.

Position **(A)** - To apply secondary brake

Position **(B)** - Neutral (No action)

Position **(C)** - To apply parking brake

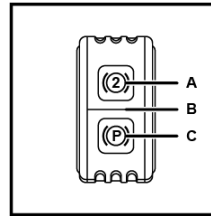

Secondary brake switch **(A)** is used to stop the machine in the event of any single failure in the service brake system only. Secondary brake system is not to hold the machine on the slope. A circuit is designed in such a way that the machine will not move forward or reverse if secondary brake switch is ON.

Press the parking brake switch **(C)** to engage the parking brake. Electrical circuit is designed in such a way that brake can be applied only when machine is in neutral. Put ON the parking brake switch before engine crank specially when the machine is on slope, to avoid the machine auto rolling as the brake auto release on engine crank.

## 9. Throttle switch

Switch for selection High/Low Engine speed.

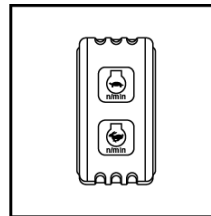

## 10. Drum selector switch

Press the upper end of the switch to select the front drum vibration. Press the lower end of the switch to select the rear drum vibration. Keep the switch in between to select both drum vibration.

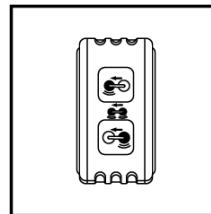

## 11. Frequency selector switch

Press the upper end of the switch to select the high frequency of drum vibration. Press the lower end of the switch to select the low frequency of drum vibration.

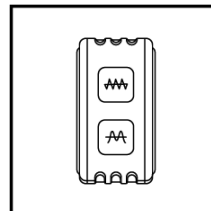

## 12. Auto idle switch

When you set this switch to ON, the engine goes to low idle speed automatically after the machine functions do not operate for a set time. When the machine functions are disturbed, the engine returns to its original RPM.

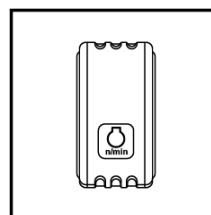

### 13. Instrument cluster

The instrument cluster displays warnings, vehicle information, and alarms received from different controllers, see 3-12.

### 14. Side and front work light (optional feature)

This switch used to ON/OFF the work light.

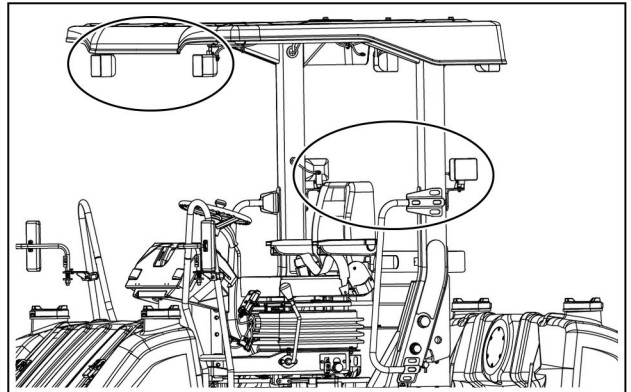

PTIL25COM0241AB 2

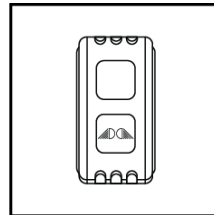

### Right-hand side controls

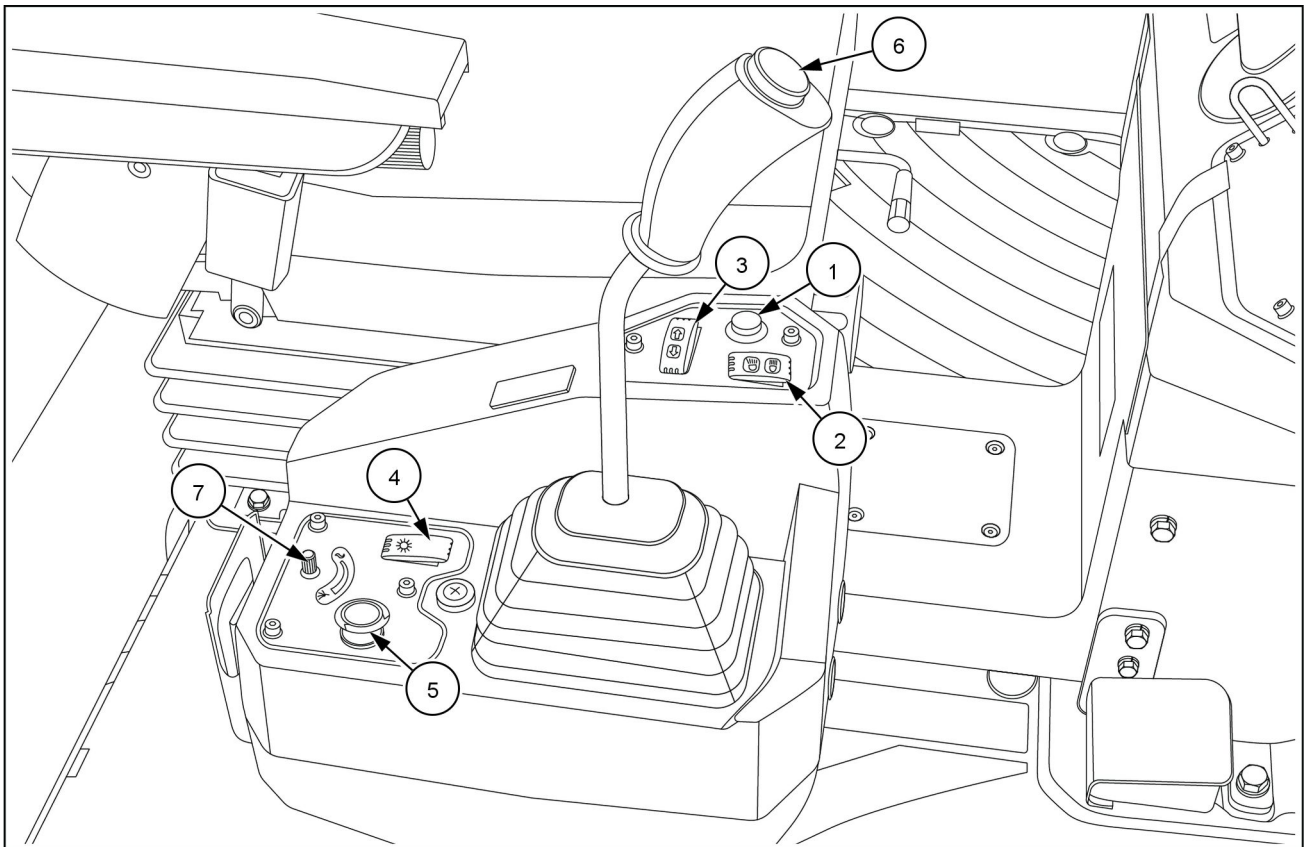

PTIL24COM1224FB 3

- |                          |                            |
|--------------------------|----------------------------|
| 1. Horn switch           | 5. Emergency stop switch   |
| 2. High/low beam switch  | 6. Vibration ON/OFF switch |
| 3. Turn indicator switch | 7. Water pump controller   |

4. Master lamp switch

**1. Horn switch**

Press the horn switch to blow horn.

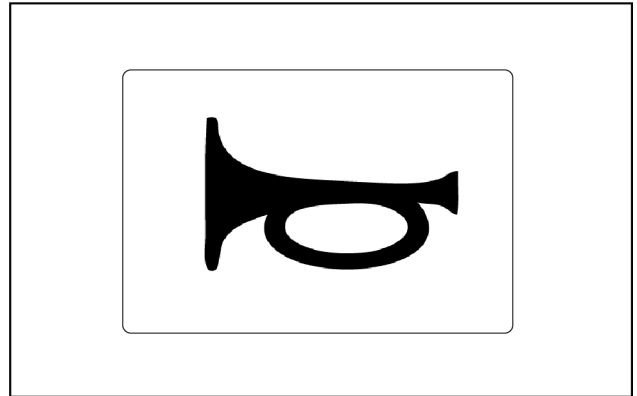

PTIL21COM0193AB 4

**2. High/low beam switch**

Press the upper end of the switch to select the high beam.  
Press the lower end of the switch to select the low beam.

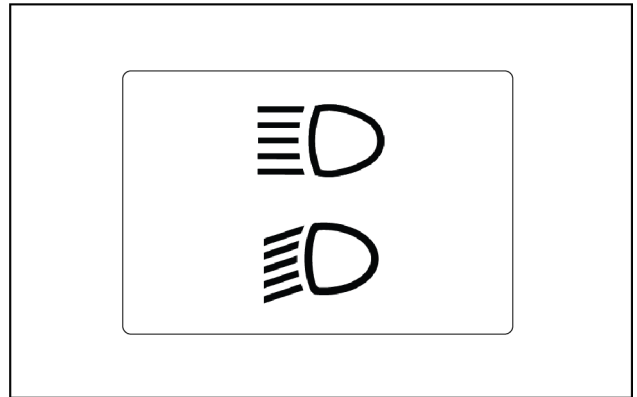

PTIL21COM0192AB 5

**3. Turn indicator switch**

Press the switch on the left-hand side to switch ON the left-hand side turn indicator. Press the switch on the right-hand side to switch ON the right-hand side turn indicator.

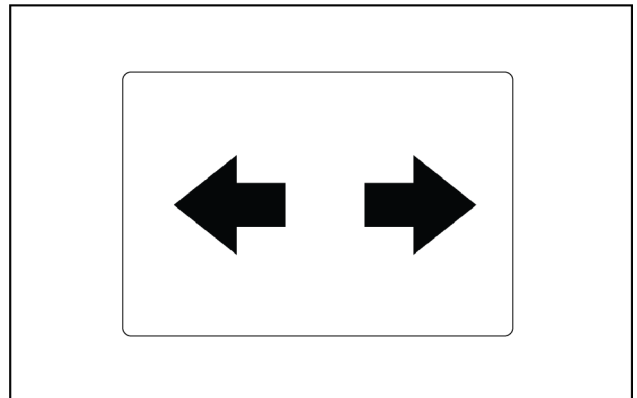

PTIL21COM0203AB 6

**4. Master lamp switch**

After pressing this switch the position lamps in both head lamps of the machine will glow.

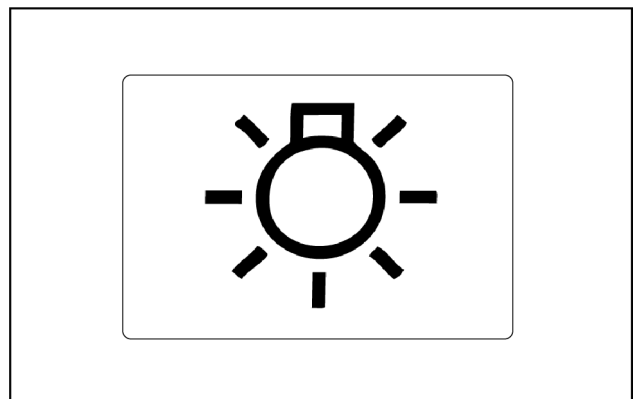

PTIL21COM0196AB 7

### 5. Emergency stop switch

Press the emergency stop switch to stop the engine.

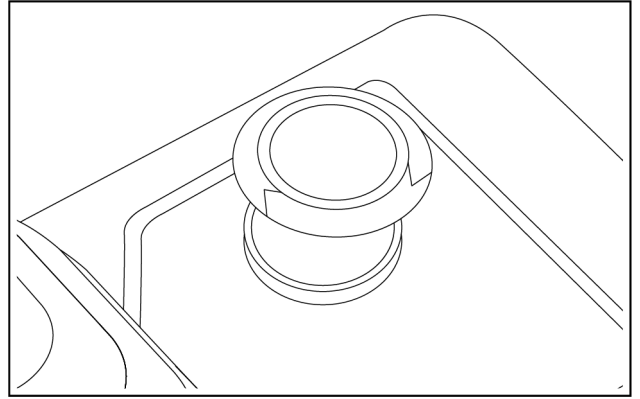

PTIL24COM1071AB 8

### 6. Vibration ON/OFF switch

Press the vibration switch to ON/OFF the vibration motor.

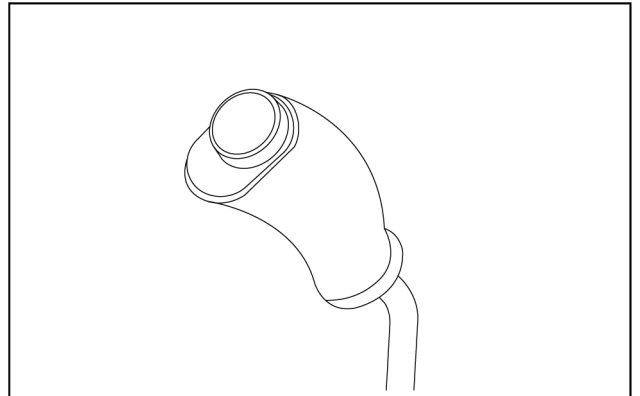

PTIL24COM1073AB 9

### 7. Water pump controller

It regulates the sprinkler system's water flow. Rotating it clockwise increases the water flow, while rotating it counterclockwise decreases the water flow.

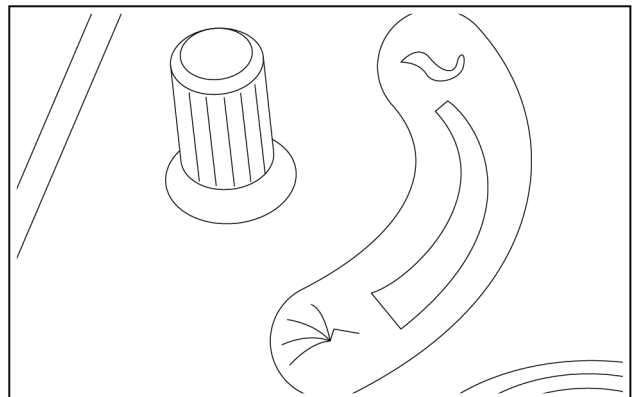

PTIL24COM1225AB 10

# Instrument cluster panel

## Indications in cluster

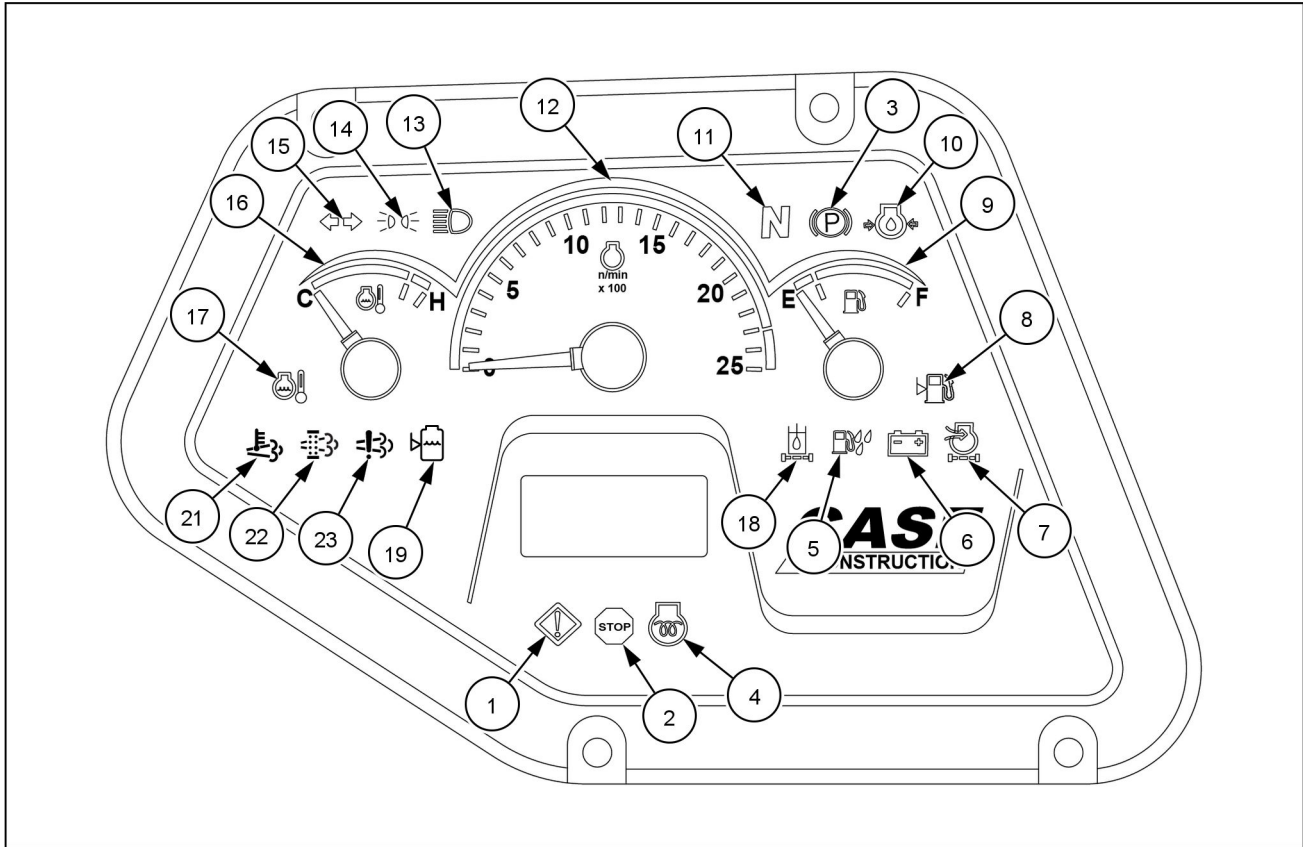

PTIL25COM0275FB 1

1.	Master warning	13.	High beam
2.	Master stop	14.	Position lamp
3.	Parking brake	15.	Turn signal (Left or right)
4.	Cold start (Glow plug)	16.	Engine coolant temperature gauge
5.	Water in fuel	17.	High coolant temperature
6.	Battery not charging	18.	Hydraulic filter clogging
7.	Air filter clogging	19.	Water level low
8.	Low fuel	20.	LCD display
9.	Fuel level gauge	21.	Engine Emission system Temperature*
10.	Engine oil pressure	22.	Engine emission filter*
11.	Neutral	23.	Engine emission system failure*
12.	Tachometer		

\* See 3-12, section "Catalyst Management" for the description.

## Instrumentation Illumination

The cluster includes the following main features

- Electronic analog tachometer
- Analog engine coolant temperature gauge
- Analog fuel level gauge (stepper motor)
- Warning lamps (LED based)

**Tachometer**

Each subdivision of the graduated scale on the tachometer represents 100 RPM, therefore with the needle indicating '20' the engine is running at 2000 RPM.

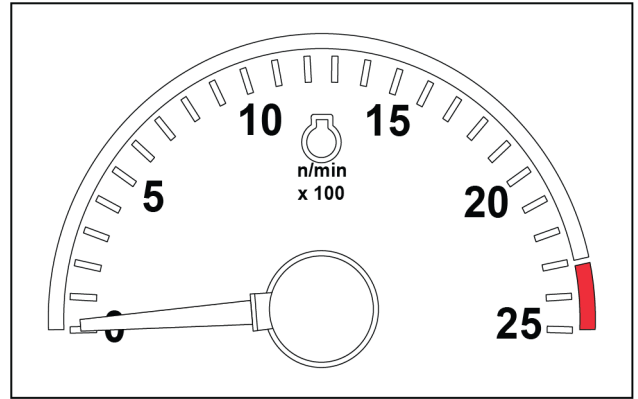

PTIL25COM0273AB 2

**Engine coolant temperature gauge**

Engine coolant temperature gauge indicates the coolant temperature. It is recommended that the coolant temperature gauge needle should not be in a red zone during operation. If the Temperature goes red zone, stop the engine and investigate.

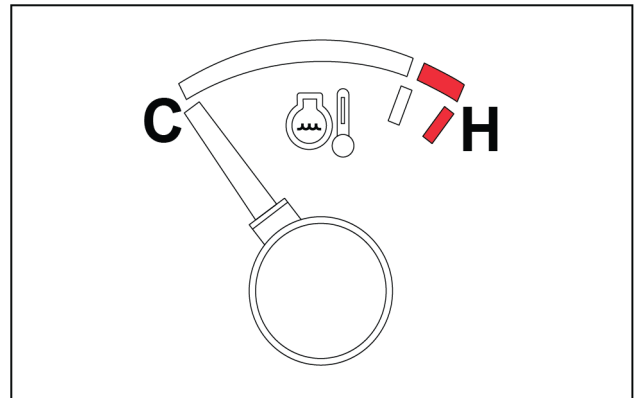

PTIL25COM0271AB 3

**Fuel level gauge**

The fuel level gauge indicates the level of fuel in the fuel tank.

**NOTICE:** Maintain a minimum of 30% of fuel in fuel tank to avoid air lock.

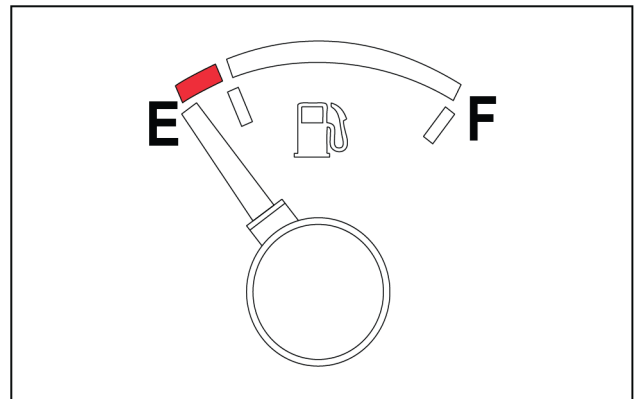

PTIL25COM0272AB 4

**Master warning**

This indicates the machine is in some warning conditions.

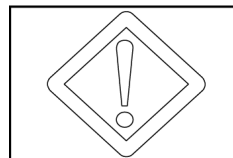

**Master stop**

This indicates the machine needs to be stopped immediately.

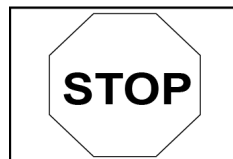

**Low fuel**

This indicates the fuel level is low in the tank and needs to be refilled immediately.

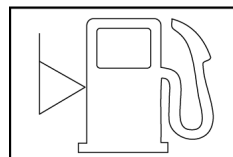

**LCD display**

This electronic hour meter is connected to the alternator. Whenever the engine is running, the hour meter starts counting. Regularly monitoring the hour meter reading will indicate the number of working hours (cumulative). This will facilitate timely maintenance / servicing of the machine.

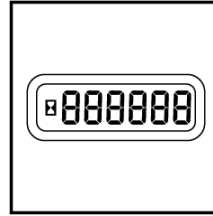
**Cold start (Glow plug)**

The indicator lamp is lit when pre heater is ON before cranking the engine in colder ambient temperatures. Cranking should be done after the lamp has turned off.

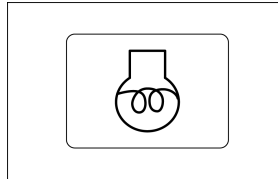
**Neutral**

This indicator comes ON when the lever is in neutral position. Engine can be started only when the FNR is in neutral position.

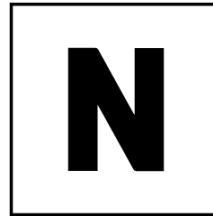
**Battery not charging indicator**

Whenever the battery is being charged the indicator goes OFF. During normal operation the indicator does not glow, which indicates that the battery is being charged. If the battery not-charging indicator comes ON during the operation of the machine, switch OFF the machine immediately and find out the reason for not-charging.

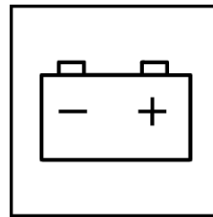
**Parking brake**

Parking brake indicator glows when parking brake is engaged. If the parking brake switch is in ON state, the parking brake disengages when the travel controller (FNR) is forward / reverse position.

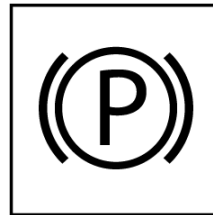
**Turn signal**

This indicator flashes when the side indicator switch is ON (i.e. moved towards left side or right side).

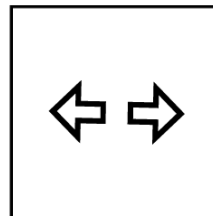
**Hydraulic filter clogged indicator**

This indicator comes ON when the hydraulic oil filter clogs. Stop the machine operation and replace the filter element. Running the machine after filter clogging will contaminate the hydraulic circuit and can cause extensive damage to the hydraulic system.

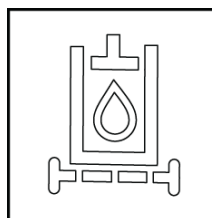

### Engine oil pressure

This indicator comes ON when the lubrication oil pressure falls below a preset level. Shut Off the engine immediately, locate the cause and set right the problem.

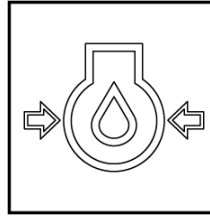

### Air filter clogging

This indicator comes ON when the air filter clogs.

**NOTICE:** If this indicator comes on, stop the vehicle and clean/replace the air filter (primary and/or secondary filter).

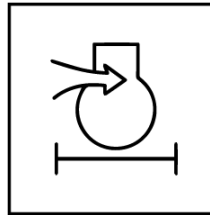

### High beam

This indicator starts to glow when high head light beam is in use.

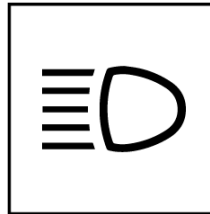

### Water in fuel

This indicator starts to glow when there water present in fuel. Stop the engine and investigate the cause.

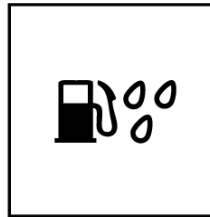

### High engine coolant temperature

This indicator starts to glow when the engine coolant temperature is high. If it starts to glow, stop the engine and investigate the cause.

If the coolant temperature is too high (as can be checked on the gauge), do not turn the engine OFF immediately.

The engine should be brought to low idle RPM and allowed to cool down as the engine fan keeps pulling fresh air. During this there should not be extra load on the engine.

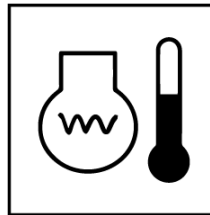

### Position lamp

This indicator starts to glow when the position lights are turned ON.

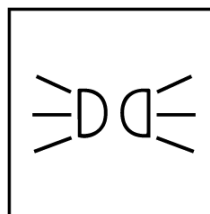

### Water level low

This indicator starts to glow when the water level in water tank is low.

**NOTE:** This indicator glows only when the machine is in neutral condition i.e. stationary.

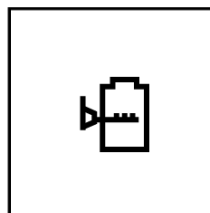



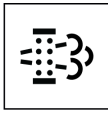

**Catalyst management**

**Active catalyst management (ACM)**

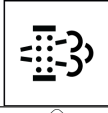
Lamp	Description	Action
	Active Catalyst Management (ACM) is in progress.	No operator action is necessary. The machine can be used during ACM. When the ACM is complete, the lamp will go off.

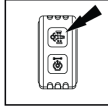
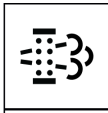
**Manual Catalyst Management (MCM)**

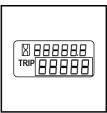
S. No	Lamp	Warning on display	Description	Action
1.	  	X	Soot is clogging the DPF, Manual regeneration required	<ol style="list-style-type: none"> <li>Park the machine away from the job, at well-ventilated area to accommodate hot exhaust and additional fumes prior to starting. And make sure the machine has approximate half tank of fuel.</li> <li>Get the machine in the safety condition by following below steps,                             <ol style="list-style-type: none"> <li>Place the F-N-R lever in the NEUTRAL position, see 3-4.</li> <li>Press throttle switch in low idle position and keep engine ON.</li> <li>Apply the parking brake.</li> </ol> </li> <li>Press regeneration switch for 3 s.                              </li> </ol>
2.	  		MCM Countdown	Wait. Regeneration has started. The approximate completion countdown will begin. The engine's RPM will automatically increase during this period, indicating that regeneration is in progress. The RPM will return to low idle once regeneration is complete. And all lamps will be OFF.

**NOTE:** If the vehicle safety condition gets interrupted or the process doesn't get completed. The lamp will glow





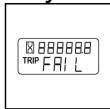

, and a

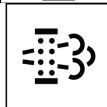

message will appear on the display.

Lamp	Description	Action
 	Extreme-level Soot is clogged the DPF	Please contact your CASE CONSTRUCTION dealer.





**After Treatment System Technical Failure**

Lamp	Description	Action
	There is a malfunction in the after-treatment system or EGR.	Please contact your CASE CONSTRUCTION dealer.
 		
 		

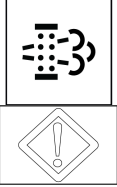

**Hydrocarbon Management**

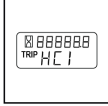
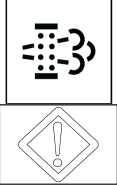
If the engine operates at low idle speed for a prolonged period, hydrocarbons can accumulate in the catalyst. To manage this accumulation, your machine will monitor current conditions and increase idle speed or request action from the operator in order to increase the temperature inside the catalyst and eliminate the hydrocarbons.

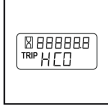
**NOTICE:** Unless the Hydrocarbon (HC) level has reached the most critical level catalyst full), running the unit under load is advantageous for quickly reducing the HC levels.

Lamp	Display	Action
 		The Engine Control Unit (ECU) will automatically increase engine idle speed to <b>1350 RPM</b> . The Engine Control Module (ECM) will allow automatic Hydrocarbon management only if the machine meets the following requirements: <ul style="list-style-type: none"> <li>• The FORWARD-NEUTRAL-REVERSE (F-N-R) lever is kept in the NEUTRAL position</li> <li>• The park brake is engaged</li> <li>• The throttle switch should be at low idle.</li> </ul>
 		The Engine Control Unit (ECU) requires the operator to increase load on the engine or increase engine idle speed to a minimum of <b>1350 RPM</b> .

**Engine Oil reset**

Display	Action
	<p>Replace the New engine oil then reset the engine oil by following the steps</p> <ul style="list-style-type: none"><li>• Switch on the ignition key.</li><li>• Place the F-N-R lever in the NEUTRAL position.</li><li>• Engine should be off.</li><li>• Apply the parking brake.</li><li>• Press Engine oil reset switch for <b>3 s</b>.</li></ul>  <p>The oil message from the display will disappear.</p>

**Telematics**

**Telematics**

This machine may be equipped with a Telematics system. This is an asset-monitoring system that combines Internet, cellular, and GPS technologies. A transponder unit is mounted on the equipment that does wireless communication with the user interface. Using cellular technology, the transponder can send equipment data, including location, on/off status, usage and production matrix, diagnostic data, movement alarms, unauthorized usage and monitor machine maintenance to the user interface. The system will help cut costs and keep accurate records. Overall The telematics system on a vehicle is used for vehicle and fleet management.

**The telematics system contains the following items:**

- The Connectivity Module installed in the vehicle to collect and transmit data.
- The wireless cellular network and internet infrastructure to exchange data between devices.
- A back-end cloud infrastructure to manage and store your data, and to deliver subscriptions wirelessly.
- An internet-connected computer to remotely access and manage your data through the connect portal.

**Once installed and activated with a valid subscription, the PCM can be used for:**

- Telematics features are available in SiteWatch™/NewHollandFleetForce portal account.

**Troubleshoot - Start-up test**

1. Key on the vehicle.
2. Confirm the Light-Emitting Diode (LED) indicators on the modem.
3. When the modem is booting, all four LED indicators will be solid green.
4. When the modem is operating normally:
  - The Power LED indicator (1) will double blink ON.
  - The CAN LED indicator (2) will be solid ON.
  - The Modem LED indicator (3) will be solid ON.
  - The GPS LED indicator (4) will be solid ON. If the Power LED indicator is solid, the device does not have a configuration applied.
- Check the device and wiring harness installation.

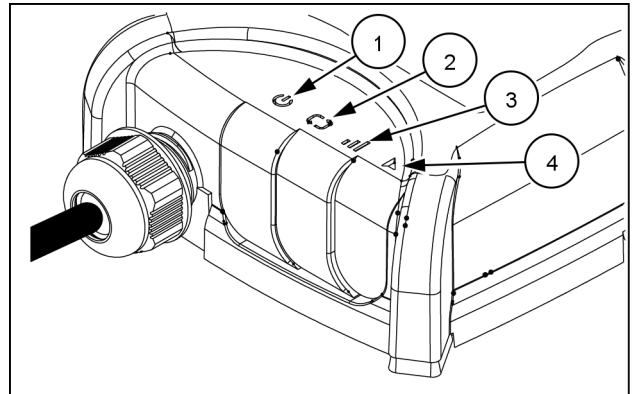

NHIL22PLM0426AA 1

**Light Emitting Diode (LED) status indicators**



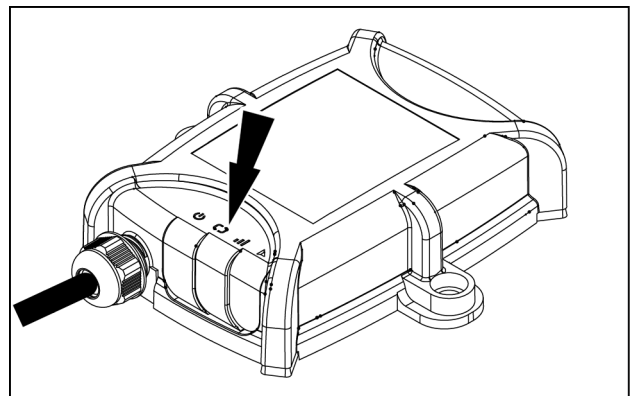

The CM100 and CM110 modem has four Light-Emitting Diode (LED) indicators for diagnostics on the following functions:

- Power
- CAN
- Modem
- GPS



NHIL22PLM300AA 2

### 3 - CONTROLS AND INSTRUMENTS

Icon	Function	Color	State	Description
	Power	Red	Off	No power supply.
			Double blink	Powered and working.
			Rapid blinking	Key is off.
			Solid	Not configured.
	CAN	Green	Off	CAN bus signal is not available.
			Solid	CAN messages receives from at least one channel.
	Modem	Green	Off	The modem is initializing. No network coverage, or device is in standby/wake mode.
			Slow blink	GSM networks are detected.
			Fast blink	The device is connected to the network, and ready to communicate with the server.
			Solid	GSM communication is ongoing.
	GPS	Green	Off	GPS is initializing, or the device is in standby/wake mode.
			Blinking	Searching for GPS signal.
			Solid	GPS position is fixed.

## 4 - OPERATING INSTRUCTIONS

### Commissioning the unit

### Commissioning operation

The following pre-operation checks has to be carried out every day before starting the engine.

- Check the fuel level in the fuel tank and top up if required.
  - Fill in diesel fuel in time so as to avoid unnecessary bleeding of the fuel system.
  - Do not spill diesel fuel on the engine.
  - If the fuel system has been run empty, it is necessary to bleed air from the system.
  - The radiator is full of coolant.
  - There is sufficient fuel in the fuel tank.
- A. Check hydraulic oil level in the tank and top up if required.
- B. Check engine oil and top up if required.
- C. Visually check for leakages and damages to electrical components and connections.
- D. Visually inspect and ensure that all the doors and covers are closed and locked. No tools like spanners, screw drivers should be left on the machine.

### Topping up the engine sump

- The engine oil level should be maintained near to H 'mark' in dipstick.
- While checking the oil level, shut down the engine. Wait for **10 min**. Withdraw the dipstick from its holder, clean and refit.
- Withdraw again and note the level. If the level goes down the "LOW" mark then contact to CASE CONSTRUCTION dealer or top up as required with the new recommended grade of engine oil.

During the first **50 h** of operation (new machine or after an engine build), make sure you do the following:

- Do not work the engine hard at stall speeds (Machine slowly turning or stopped and the engine running at full throttle).
- Keep the engine at normal operating temperature.
- Do not run the engine at idle speed for long periods of time.

### Engine speed

It is suggested that you run the engine at full throttle when operating conditions permit and when safe.

Do not run the engine at idle speed for long periods. This can cause low operating temperature. Low operating temperature can cause acids and deposition in the engine oil.

### Frost precautions

If anti-freeze solution is not in use and the engine has to be left in the open with temperatures close to freezing point, the cooling system must be completely drained by opening the two drain points which are situated as follows:

- Drain Plug fitted at the rear right hand side of the cylinder block.
- Drain coolant from Radiator drain plug fitted at the radiator bottom tank.
- Drain tap/plug should be tested at frequent intervals by inserting a length of wire to ensure that they are clear.
- This should be done as soon as they are opened, so that an obstruction freed by the wire may be flushed out by the water.
- After draining, place a notice on the engine to the effect that the cooling system is empty and the drain taps/ plugs are open.

**NOTE:** Engine with anti-freeze mixture in their cooling systems, need not drain the cooling system.

## Before using the machine

**NOTICE:** Read and familiarize yourself with the instructions and warnings shown in this manual before operating the machine.

- Before using the machine, some precautions are necessary.
- Check the levels (engine oil, hydraulic fluid and coolant fluid) and make sure that the various fluids correspond to the conditions of use.
- Carry out the daily maintenance operations.
- Walk round the machine, look for any leaks and inspect the hoses. Tighten or replace any items as required.
- Before undertaking road travel and install the safety systems required by the regulations.
- Before road travel or night work, check that the lighting and signaling systems are correctly operating and correctly adjusted.
- Clean the steps and access handles.
- The presence of oil, mud or ice (winter) can cause accidents.
- Make sure that the safety signs are always clean.
- Clean or replace safety signs which are no longer legible.
- Make sure that the engine tilt hood is closed and latched correctly.
- Remove anything which might hinder visibility. Clean the windows and the rearview mirrors.
- Make sure that no objects or tools are left on the machine or in the operator's compartment.
- Make sure you know how to evacuate the machine in case exit through the left-hand door is impossible.
- Make sure that nobody is under or on the machine.
- The operator should be the only person on the machine.
- Make sure that nobody is within the working range of the machine.

## Operating the machine

### **▲ WARNING**

#### **Driving hazard!**

**Check all controls and safety devices in a safe, open area before starting work.  
Failure to comply could result in death or serious injury.**

W0248A

When using the machine, follow the safety precautions mentioned in this manual.

Start the engine taking into account weather conditions.

Regularly check the hourmeter on the side instrument display to ensure servicing intervals are observed.

If you use the machine under particularly severe conditions (dusty or corrosive atmosphere, etc.), reduce the service intervals.

Make sure that the operator's seat is correctly adjusted and positioned.

Never operate any control or driving component unless you are seated correctly in the operator's seat with the seat belt adjusted and attached correctly.

### **▲ WARNING**

#### **Inhalation hazard! Risk to operators and bystanders.**

**Avoid running the engine in confined areas. Make sure there is adequate ventilation at all times.**

**Failure to comply could result in death or serious injury.**

W0156A

**NOTICE:** *Dust, smoke or fog can reduce visibility and may cause an accident. Stop or slow down the machine until normal visibility is restored.*

If there is any operating problem, immediately engage the parking brake and stop the engine.

Find the cause or inform responsible persons and take the necessary measures to forbid the use of the machine.

When stopping the engine take account of weather conditions. See **Shutting down the engine**.

When loading the machine onto the trailer, see **5-1**.

When towing the machine, see **5-4**.

### **Road operation**

**NOTICE:** *Road speed is subject to restrictions according to the country. It is the operator's responsibility to follow the road speed limitations.*

Before carrying out any road travel, lock the attachments and install the safety systems required by regulations.

The machine must be within the maximum dimensions permitted on the road in accordance with local road traffic regulations.

Check that the lighting and signaling systems operate correctly.

Check that the brakes and steering operate correctly.

Never leave the operator's compartment when the engine is running.

### **Job site operation**

On job sites on the public highway, use regulation signals, taking into account the working range of the machine.

Local regulations define the number, type and location of reflective strips.

Be vigilant, be aware of places where other persons are working close to your working area.

**NOTICE:** *Keep other persons away from the machine. Serious physical injury can result if these instructions are not observed.*

Adapt your driving style to suit the conditions of work (sloping ground or rough ground), the state of the road and weather conditions.

Operate all controls consistently so the machine works smoothly.

**NOTICE:** *Holes, obstacles, debris and other hazards in the working area can cause serious physical injury. Always walk around and identify all possible hazards before operating the machine in a new working area.*

Make sure you know the location of underground pipes or cables before beginning work.

**NOTICE:** *Electrical cables, gas pipes, water pipes or other underground installations can cause serious physical injury.*

Do not work close to live overhead electric lines without first making sure that the minimum distances are observed: **5 m (16.4 ft)**.

## Starting the unit

## Starting the unit

### Starting the engine :

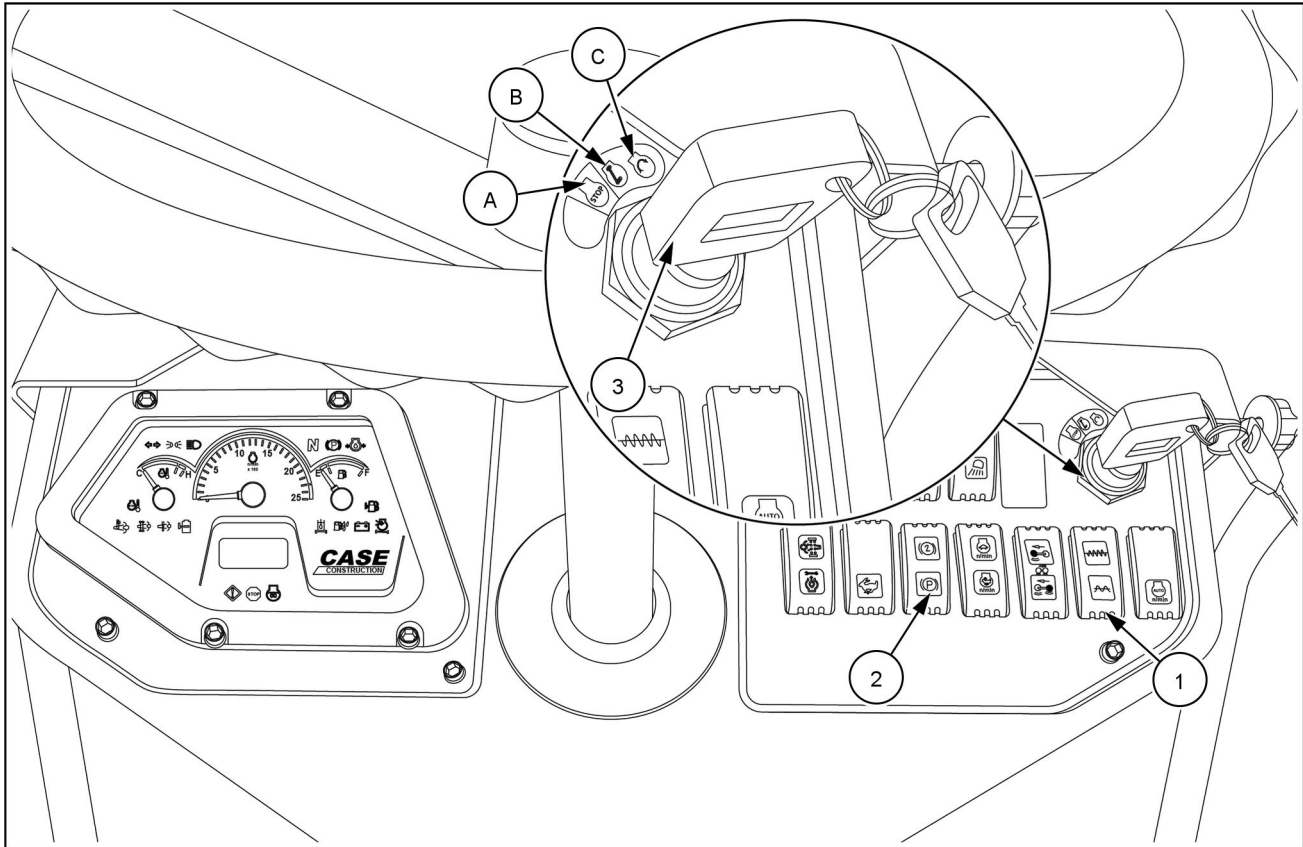

PTIL24COM0889FB 1

1. Make sure that the articulation frame lock is removed.
2. Make sure that the transmission lever (FNR) is in neutral position (see 3-4) and neutral indicator is glowing in the instrument cluster.
3. Vibration selector switch (1) must be in neutral position.
4. Put ON the parking brake switch (2) before engine crank specially when the machine is on slope, to avoid the machine auto rolling as the brake auto release on engine crank.
5. Insert the ignition key (3) into the ignition switch and rotate clockwise to position (B). Now check all indicators.
6. Turn the ignition key (3) further clockwise to position (C) and hold the key for few seconds to start the engine.

**NOTICE:** Do not actuate the ignition key for more than 5 s for engine starting. If the engine does not start, wait for one minute before trying again. Do not turn the Ignition key while engine is running as it will damage the starter motor. Avoid frequently turning the ignition key ON and OFF when the engine is off or the machine is stationary. Before turning again the ignition key, move the ignition key back to (A) and then move to (B) and then (C).

7. Run engine at low idle speed for 2-3 min and use throttle switch and switch to high idle.

**NOTICE:** Machine must be operated (travel as well as vibration) in high engine rpm only.

### Starting the machine using jump leads (booster cables)

**▲ DANGER**

**Explosion hazard!**

**When jump-starting the machine, connect and disconnect the jumper cables exactly as indicated in this manual. DO NOT connect the jumper cables to the machine battery terminals. Make sure no persons are near the connecting points before starting the engine. Start the engine from the operator's seat.**

**Failure to comply will result in death or serious injury.**

D0208A

**▲ DANGER**

**Explosion hazard!**

**If battery electrolyte is frozen, attempting to charge the battery or jump-start the engine can cause the battery to explode. Always keep batteries at full charge to prevent frozen battery electrolyte. Never charge a frozen battery.**

**Failure to comply will result in death or serious injury.**

D0183A

If it is necessary to use jump leads (booster cables) to start the machine, use only heavy duty leads and proceed as follows:

1. Connect one end of the red jump lead to the machine battery positive (+) terminal and the other end to the auxiliary battery positive (+) terminal.
2. Connect one end of the black jump lead to the machine battery negative (-) terminal and the other end to the auxiliary battery negative (-) terminal. Follow the starting procedure previously described.
3. When the engine starts, allow it to run at idle rpm. Turn on all electrical equipment (lights, etc.) then disconnect the jump leads, negative (black) first then positive (red). This will help protect the alternator from possible damage due to changes in load.

## Stopping the unit

# Stopping the unit

### Setting the machine out of operation

- Before you leave the machine, make sure the machine is parked on a level surface.  
***NOTE:** The machine must be on level ground before you do scheduled maintenance.*
- Turn the frequency selector switch to neutral (at centre) to stop the vibration.
- Bring the drum selector switch to centre.
- Then bring FNR lever to neutral to stop travelling and neutral indicator is glowing in the instrument cluster.
- Switch ON the parking brake during parking the machine especially on slope to prevent the machine from rolling.
- Make sure to run the engine at low idle for **2 – 3 min** before shutting down.
- Turn the ignition key anti-clockwise to position **(A)**. See **4-4**. All the indicators should go off.
- Secure the machine by means of drum chocks and / or stone / rocks if necessary.  
***NOTICE:** Shutting down the engine when at a higher idle RPM will damage the turbocharger.*
- ***NOTE:** If you must temporarily park the machine on a hillside, put the front of the machine toward the bottom of the hill. Make sure the machine is behind an object that will not move.*
- In case there is an emergency, vehicle can be stopped using emergency stop switch.
- Before next cranking please make sure that the emergency stop switch is unlatched (OFF position).

## Moving the unit

# Moving the unit

### Before operating the machine

#### **▲ WARNING**

**Equipment failure could cause accident or injury!**

**Before operating the machine, check for correct operation of steering, brakes, hydraulic controls, instruments, and safety equipment. Make sure the transmission control lever is in the neutral position.**

**Make all adjustments before operating the machine.**

**Failure to comply could result in death or serious injury.**

W0204A

Check the instrument panel

Turn the key switch to the ON position and verify that warning/ indicator lights illuminate and turn off as designed.

Test the parking and secondary brakes.

**NOTE:** Review the procedures in their entirety before proceeding. Ensure you allow surplus room for machine travel on slope.

### To test the parking brake:

1. Ensure the operator's seat is in normal position.
2. Ensure that articulation joint arrestor is disengaged.
3. Ensure that parking brake is not engaged (parking brake should be in off position).
4. Start up the engine.
5. Run the engine for **2 – 3 min** at low idle.
6. Increase the engine speed to full throttle.
7. Travel forward on slope.
8. On slope put the FNR lever in neutral and engage the parking brake & shutdown the engine.
9. Parking brake will hold the m/c.
10. Contact your dealer for services as needed.

The hydrostatic system constitutes the service brake thus a separate service brake is not required. The spring loaded multiple disc brakes in the rear travel motor serves as a parking brake.

### Operating the machine (travel)

1. Take off the machine with the drive lever in to the desired driving direction.

**NOTE:** The engine must run at its high idle speed when driving the machine. If the drive lever is moved forward from neutral position, the machine will move forward. If the drive lever is moved backward from neutral position the machine will move backward.

2. The speed will increase, the more the lever is moved forward or backward.
3. For braking, move the drive lever out of the respective forward or reverse driving position to the zero position

**ATTENTION:** In case of danger but only if a disturbance and/or breakdown of the service brake is involved engage the parking brake by actuating the parking brake switch. The machine will stop instantly. Actuate the parking brake only for a real emergency braking operation so as to avoid premature wear and tear of the parking brake.

### Setting the vibration into operation :

Turn the vibration selection switches viz double drum or single front drum vibration mode, see **3-6**.

Turn on vibration cutoff switch and select HF or LF as per requirement, see **3-6**.

**Setting the sprinkler into operation :**

Use the water pump switch available on the machine for water sprinkling system, see 3-6.

**Machine and operator visibility**

**Machine and operator visibility**

**⚠ WARNING**

**Equipment failure could cause accident or injury!**

**Before operating the machine, check for correct operation of steering, brakes, hydraulic controls, instruments, and safety equipment. Make sure the transmission control lever is in the neutral position.**

**Make all adjustments before operating the machine.**

**Failure to comply could result in death or serious injury.**

W0204A

- Two mirrors are provided for the operator's visibility, one on the left-hand side and one on the right-hand side.
- The operator is required to survey their field of vision before operating the machine. This means being aware of their surroundings, checking for obstacles, and ensuring clear visibility to prevent accidents.
- Regularly clean reflector, safety decals and other visual aids to maintain machine visibility.
- Always ensure working area of job-site enclosed with traffic cones or barricades and other safety equipment.
- Modifications which affect the operator and machine visibility are strictly prohibited.
- While operating the machine working lights and head lamp may be switched on, make sure no other road users or workers dazzled by lights.
- To avoid rear view mirror vibration always operate machine at high idle speed.
- During operations the SMV-plate at the rear of the earth-moving machine may be folded away or detached.
- Position mirrors correctly: Adjust mirrors to cover blind spots and provide a clear view of the surroundings, refer image 1 and 2.
- Regularly check mirrors: Ensure they are clean and properly adjusted. These aids enhance visibility and safety.

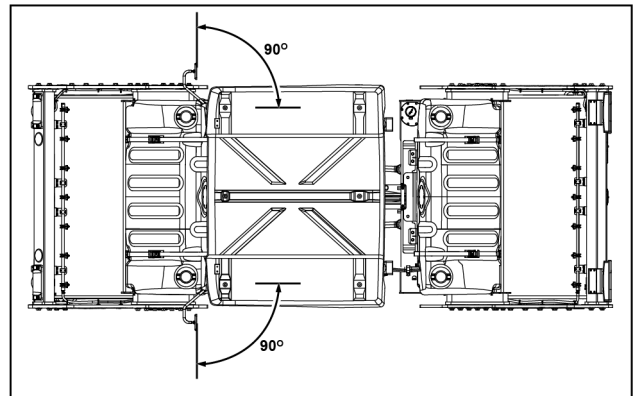

PTIL24COM1095AB 1

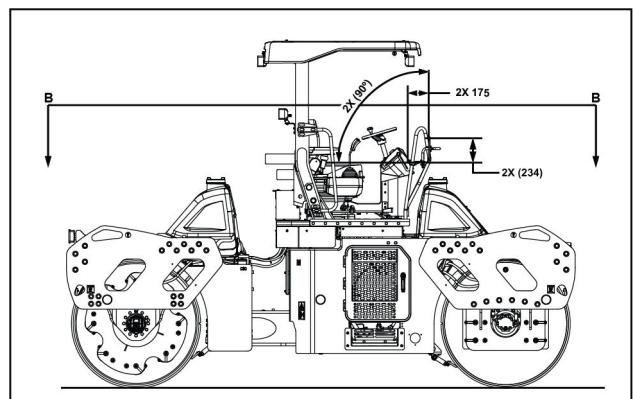

PTIL25COM0212AB 2

### Operating the machine :

Drive the machine with the F-N-R lever (1) in to the desired driving direction. If the F-N-R lever (1) is moved forward from neutral position, the machine will move forward. If the F-N-R lever is moved backward from neutral position the machine will move backward. The speed will increase, the more the lever is moved forward or backward, see 3-4.

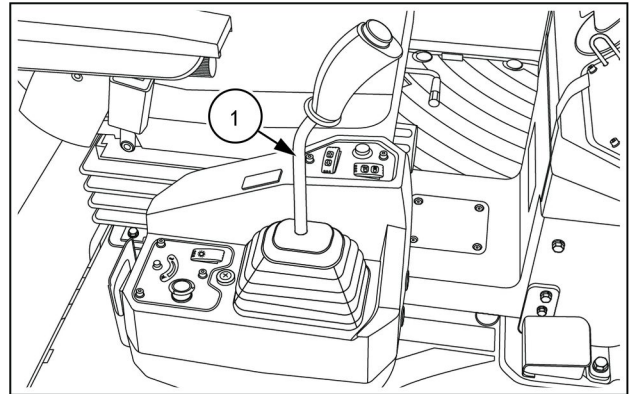

PTIL24COM1188AB 3

For braking, move the drive lever out of the respective forward or reverse driving position to the neutral position. During parking in slope, put on parking brake switch (1) to apply parking brake.

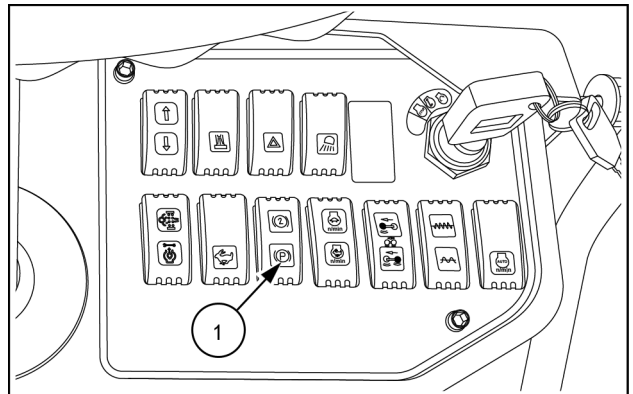

PTIL24COM1133AB 4

### Setting the exciter shaft into operation (vibration)

Start the engine according to the procedure given above. Start moving (forward or reverse direction) the machine in working speed (turn OFF the high speed switch (1)). Press vibration frequency selector rocker switch (3) on the top to select high frequency and low amplitude. Press vibration frequency selector rocker switch (3) on the bottom to select low frequency and high amplitude. To select single drum vibration, first select rear drum or front drum vibration by pressing the drum selector switch (2) in machine. Then start moving the machine in forward or reverse direction and then turn ON frequency selector rocker switch (3).

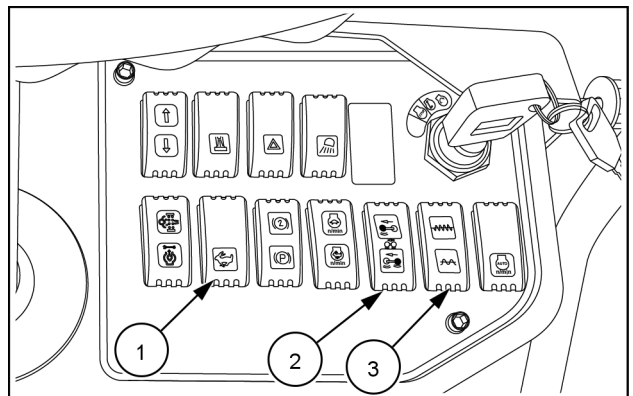

PTIL24COM1133AB 5

### Setting sprinkler into operation

To start water pump, first switch ON water pump switch (1).

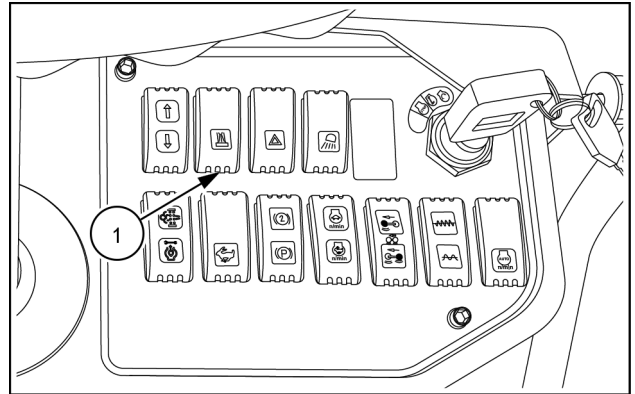

PTIL24COM1133AB 6

### Setting other features into operation

Switch ON/OFF parking light, head lamp ,rear light, side indicator hazard if required. Move the operator seat by pulling the seat locking knob if required. See 3-2.

**NOTE:** Parking light must be ON before switching ON the head light. After switching ON parking light and head light set the headlight beam (high/dipper) beam as required.

## 5 - TRANSPORT OPERATIONS

### Preparing for road transport

### Transport dimensions

For machine dimension, see 9-2.

### Shipping transport

### Transporting on a trailer

#### ⚠ WARNING

##### Transport hazard!

The machine can slip or fall from a ramp or trailer. Make sure the ramp and trailer are not slippery. Remove all oil, grease, ice, etc. Move the machine on or off the trailer with machine centered on the trailer or ramp.

Failure to comply could result in death or serious injury.

W0152A

**NOTICE:** The machine must be secured on its trailer with appropriate latches, wedges, drum chocks etc. during transport to avoid oscillatory movements in transit. The parking brake is not designed to ensure this "dynamic braking".

You must know the rules or laws for safety that are used in each area that you will be in. Make sure that the truck and trailer are equipped with the correct safety equipment.

#### Load the machine onto a trailer:

1. Put a block at the front and rear of the trailer wheels.
2. Fasten the seat belt and apply the parking brake. Slowly drive the machine onto the trailer.

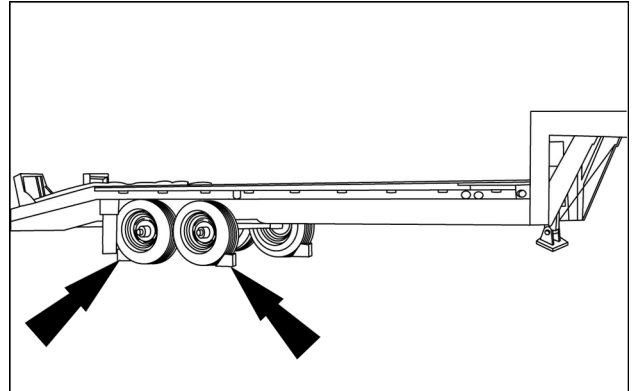

RCPH10TLB056AAF 1

3. Move the FNR lever to the neutral position.
4. When loading and transporting rollers with the aid of hoists provide suitable means of slinging or fastening at the points provided for this purpose. Remove the pin (1). Using the same pin (1) lock the articulation frame lock (2) in hole (3) before loading the machine.
5. Stop the engine and remove the ignition key.
6. Install a wheel chock in front of and behind each roller of the machine.

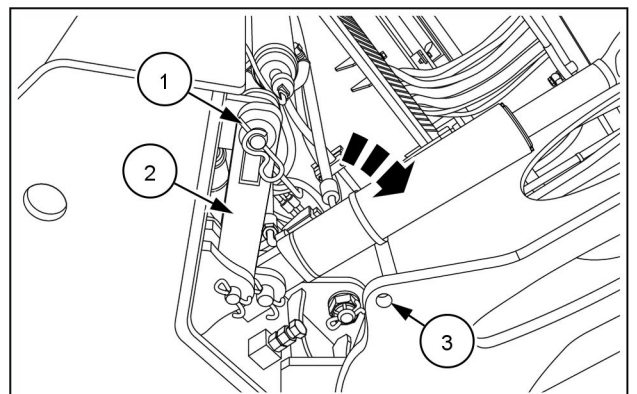

PTIL24COM1142AB 2

## 5 - TRANSPORT OPERATIONS

- Use chains and binders to secure the machine to the trailer. Attach them to the tie-down points.

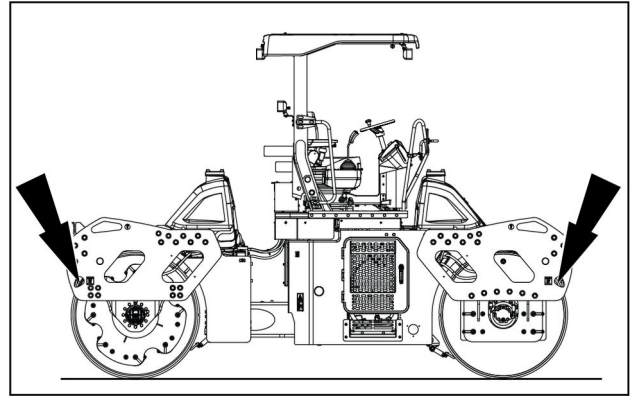

PTIL25COM0191AB 3

- Hold the canopy post (4), slowly loosen the two bolts (5) and (6) on the both the sides canopy post (4).
- Remove bolt (5) both sides and rotate the canopy about bolt (6) until the stopper bracket (7) touches the canopy leg (8).
- Once the hole in the stopper bracket (7) is aligned with the hole in canopy leg (8). Insert the bolt (5) in this hole on both the sides.

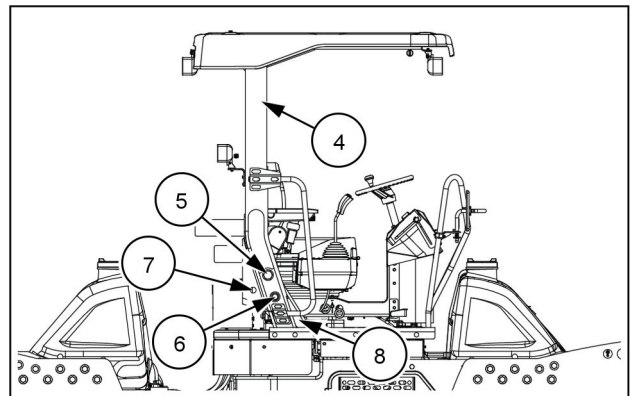

PTIL25COM0193AB 4

- Tighten the bolts on each side. Make sure the canopy (4) does not touch other parts. The height of the machine with lowered canopy (H) is 2990 mm (118 in).

**NOTE:** When the machine arrives at the work site, return the canopy to its original position. Tighten the canopy post bolts (5) and (6) to a torque of 980 – 1078 N·m and 690 – 760 N·m respectively.

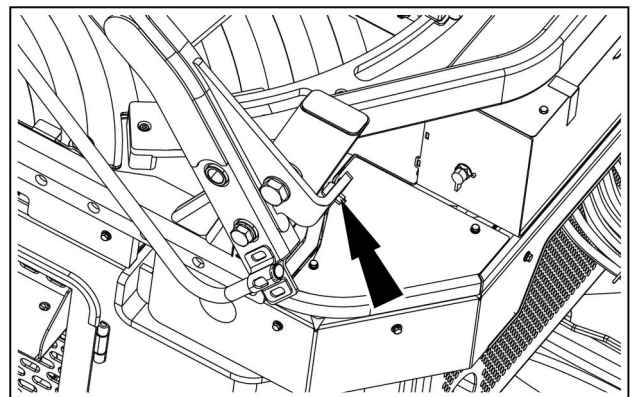

PTIL25COM0301AB 5

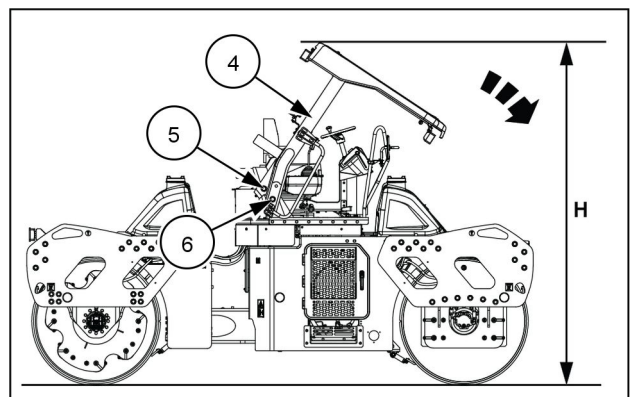

PTIL25COM0300AB 6

## Lifting points

### **⚠ DANGER**

#### **Heavy objects!**

**Lift and handle all heavy components using lifting equipment with adequate capacity. Always support units or parts with suitable slings or hooks. Make sure the work area is clear of all bystanders. Failure to comply will result in death or serious injury.**

D0076A

**NOTICE:** Before lifting the machine, it is essential to attach articulation lock.

**NOTICE:** Never use any other hooking points than those shown by the signs.

1. Use two lifting points at the front **(1)** and two lifting points at the rear **(2)** to lift the vehicle.
2. Make sure that the slings are in perfect condition and that they can support the weight of the machine.

**NOTICE:** Do not allow anybody within the machine's working range. Never suspend the machine over people who are in proximity.

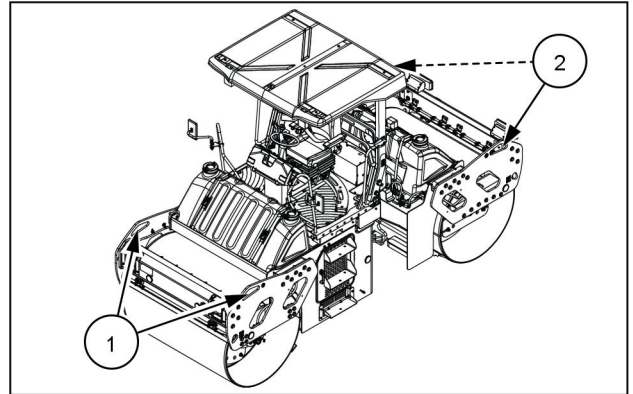

PTIL25COM0211AB 1

## Recovery transport

### Towing the machine

#### ⚠ WARNING

Loss of control!

Only tow at safe speeds. Use caution when making corners or meeting traffic.

Failure to comply could result in death or serious injury.

W0126A

**NOTICE:** Towing the compactor is not suggested.

**NOTICE:** The compactor engine should not be started by towing the machine.

If your machine is disabled, you must make a judgment if the machine can be moved without damage. If possible repair the machine at the job site.

The machine must be attached as close as possible.

The disabled machine must be moved only far enough to reach a safe repair location or on to a trailer.

Before moving a disabled machine, you must be able to answer these questions:

- Does the towing machine have braking and steering capacity for both the rollers?
- Does the towing hardware, chains, cables have the proper capacity to move the machine safely?
- Will moving the machine cause damage to moving parts that lack lubrication?

Additional considerations

- Be certain that all personnel involved are shielded in the event that towing apparatus might break.
- An operator may only be allowed on the towed vehicle if it has steering and braking capability.

#### Towing

Use the lugs at the front and rear roller frame for towing.

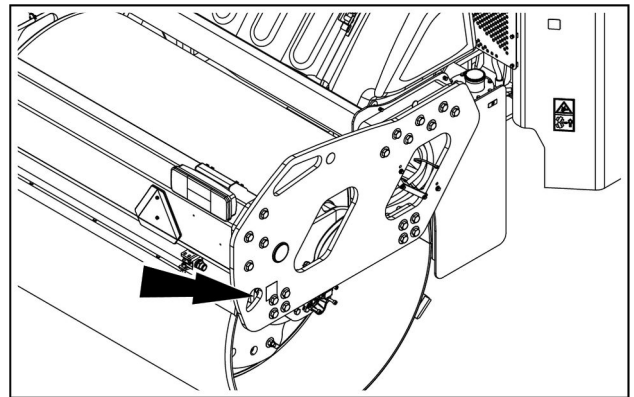

PTIL24COM1132AB 1

## Releasing the brake

- Fix the articulation frame lock. See 5-1.
- Interconnect “A” and “B” port of travel pump (1) by pressing the plungers (2) on the main relief valve (or multi function valve), see image 3.

**NOTE:** These plungers are accessible from the bottom of the pump when mounted on machine.

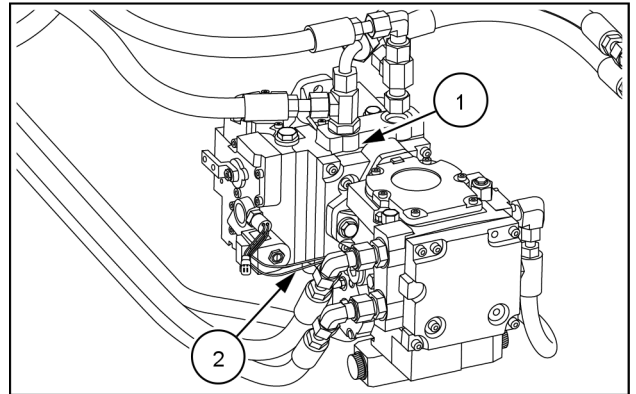

PTIL21COM0862AB 2

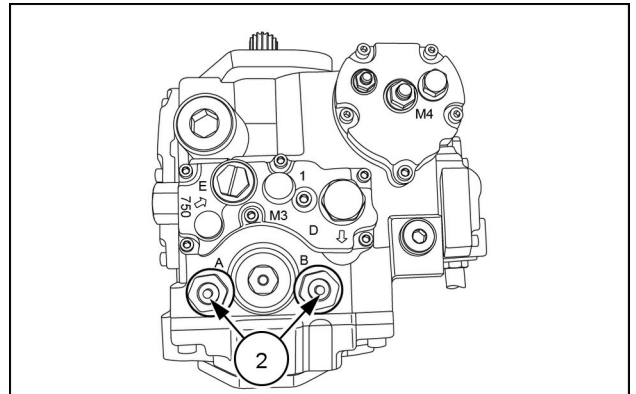

PTIL17COM1109AA 3

## Foot pump

Foot pump is connected in brake circuit for releasing parking brake in case if machine is required to be towed when there is a failure in engine and it cannot be started due to unforeseen reason.

Rotate the two-way ball valve (1) provided in circuit t to closed position and operate the foot pump (2) till the time machine should start moving. Before machine towing, release the parking brake.

- Open the left-hand side engine compartment door.
- Open the two-way valve (or ball valve) (1) by turning it anti-clockwise by 90°.
- Pressurize the brake circuit by operating the foot pump (2) positioned on operators stand (left-hand rear side).
- Make sure parking brake switch is in OFF condition. See **Forward controls**.

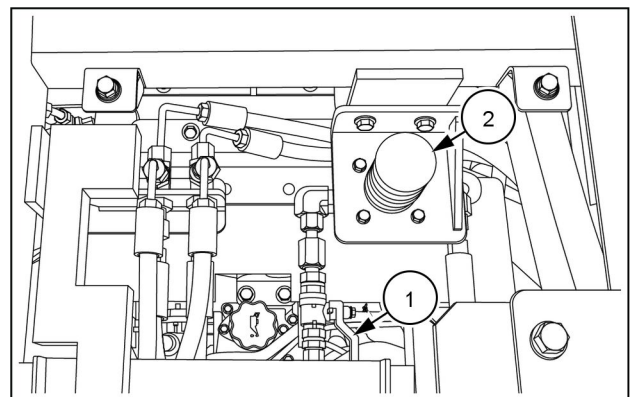

PTIL24COM1141AB 4

**NOTE:** The towing speed should not exceed 3.0 km/h (1.9 mph). Restrict any towing operation to the bare minimum.

### **Tow procedure - engine runs**

**NOTE:** Close the valve manually, release only in case of engine not working.

1. Engage the parking brake.
2. Block the drums with drum chocks.
3. Place the travel controller (FNR) lever in neutral.
4. Attach the rigid drawbar to the towing machine. Make sure the towing machine has enough power and ability to move and stop.
5. Remove the drum chocks.
6. Release the parking brake. If the parking brake does not disengage, disable the parking brake manually.
7. No riders allowed. Ensure all other workers are out of the area.

### **Tow procedure - engine does not run**

1. Block the drums with drum chocks.
2. Place the travel controller (FNR) lever in neutral.
3. Attach a rigid drawbar to the disabled machine.
4. Attach the rigid drawbar to the towing machine. Make sure the towing machine has enough power and ability to move and stop.
5. Remove the drum chocks.
6. Release the parking brake. If the parking brake does not disengage, disable the parking brake manually.
7. No riders allowed. Make sure all other workers are out of the area.

**NOTICE:** After repairing the disabled machine, return both drum drive brake by rotating two-way ball valve to original position.

## 6 - WORKING OPERATIONS

### General information

### Operating the machine during running-in period

#### **▲ WARNING**

**Avoid injury and/or machine damage!**  
**During the run-in period for new machines or after overhaul, be aware that brakes may be less efficient and longer stopping distances may be required.**  
**Failure to comply could result in death or serious injury.**

W1073A

When putting a new machine into operation, the machine should not be run at full power for the first **50 h** (driving uphill with vibration).

### Operating the machine at high altitudes

Engine power is affected by the environment in which the machine is operated.

**NOTICE:** *Air density decreases as altitude or ambient temperature increases. As a result of this, the engine's maximum output, quality of exhaust gas, temperature level and, in extreme cases, starting behavior, are impaired. This machine shall operate normally at a maximum altitude of **1600.00 m (6292.13 in)** (without de-aeration). At **2000 m**, there will be **10%** performance reduction and at **3000 m** and above, there will be **20%** performance reduction.*

**NOTE:** *If the engine will be operated under severe conditions (at higher altitudes than specified) contact the CASE CONSTRUCTION dealer for further guidelines.*

### Operating the machine at high temperatures and humidity

The higher the air temperature and humidity, the lower the engine performance. Both factors reducing performance are dependent on each other:

**NOTE:** *The machine shall operate normally at temperatures up to **50 °C (122 °F)** for mobile operations.*

**NOTICE:** *It is not recommended to operate the engine beyond specified temperature.*

## Operating the machine at low temperatures

**NOTICE:** The cold start capability of machine is up to **-15.0 °C (5.0 °F)** at **1600.00 m (62992.13 in)**.

**NOTE:** If the engine will be operated under severe conditions (at lower temperatures than specified) contact the CASE CONSTRUCTION dealer for further guidelines.

**NOTICE:** Normal engine coolant operating temperature is **75 – 100 °C (167 – 212 °F)**.

**NOTICE:** The machine may only be used at its full capacity after fluid has been heated to its minimum operating temperature.

**NOTICE:** Never start the machine below **-15.0 °C (5.0 °F)**.

Preparation for work at any condition.

1. Check concentration of the engine coolant.
2. Use hydraulic oil of corresponding kinematic viscosity.
3. Use winter fuel.
4. Check that the batteries are charged.

**NOTE:** If necessary, remove the batteries and store them in a warm room prior to operation. Warming the batteries to approximately **20 °C (68 °F)** will lower the maximum cold starting temperature an additional **4 – 5 °C ( 7.2 – 9.0 °F)**.

## Operating the machine in extremely dusty environment

The aftercooler and radiator cleaning intervals.

When working in an extremely dusty environment, shorten the intervals between:

- Cleaning the aftercooler.
- Cleaning the radiator and oil cooler fins.

**NOTE:** The air filter element has to be replaced only when the clog indicator comes ON.

**NOTE:** The recommended cleaning interval is a minimum of once a week.

---

## Operating with vibration on compacted and hard materials

### **⚠ DANGER**

**Avoid injury!**

**If you operate the machine in Vibration mode with a ballasted compaction drum, you will damage the Anti-Vibration Mounting (AVM) pads. This can cause the drum to separate and lead to unpredictable machine movement. Never use Vibration mode when you ballast the compaction drum.**

**Failure to comply will result in death or serious injury.**

D0210A

### **⚠ WARNING**

**Avoid injury and/or machine damage!**

**Prolonged operation in this mode is prohibited, as it could negatively impact operator health or cause machine damage.**

**Failure to comply could result in death or serious injury.**

W1070B

When operating the machine with vibration on hard materials (e.g. stony loose material), or with high level of base material compacting, there can be a loss of contact between the drum and the material compacted, called vibro-stroke. Vibro-stroke can be detected through increased vibration transfer to the machine frame and the operator control stand. Reduce the possibility of vibro-stroke by increasing the travel speed or use the vibration switch to select the lower amplitude setting.

If it is necessary to operate the machine under conditions in which the operator could be exposed to increased vibrations, then the machine operator is obligated to adjust work procedures to prevent impairment of the operator's health.

**WORKING OPERATIONS****Water pump safety measures in cold regions**

For operations in cold regions (Temperature  $\leq 0$  °C):

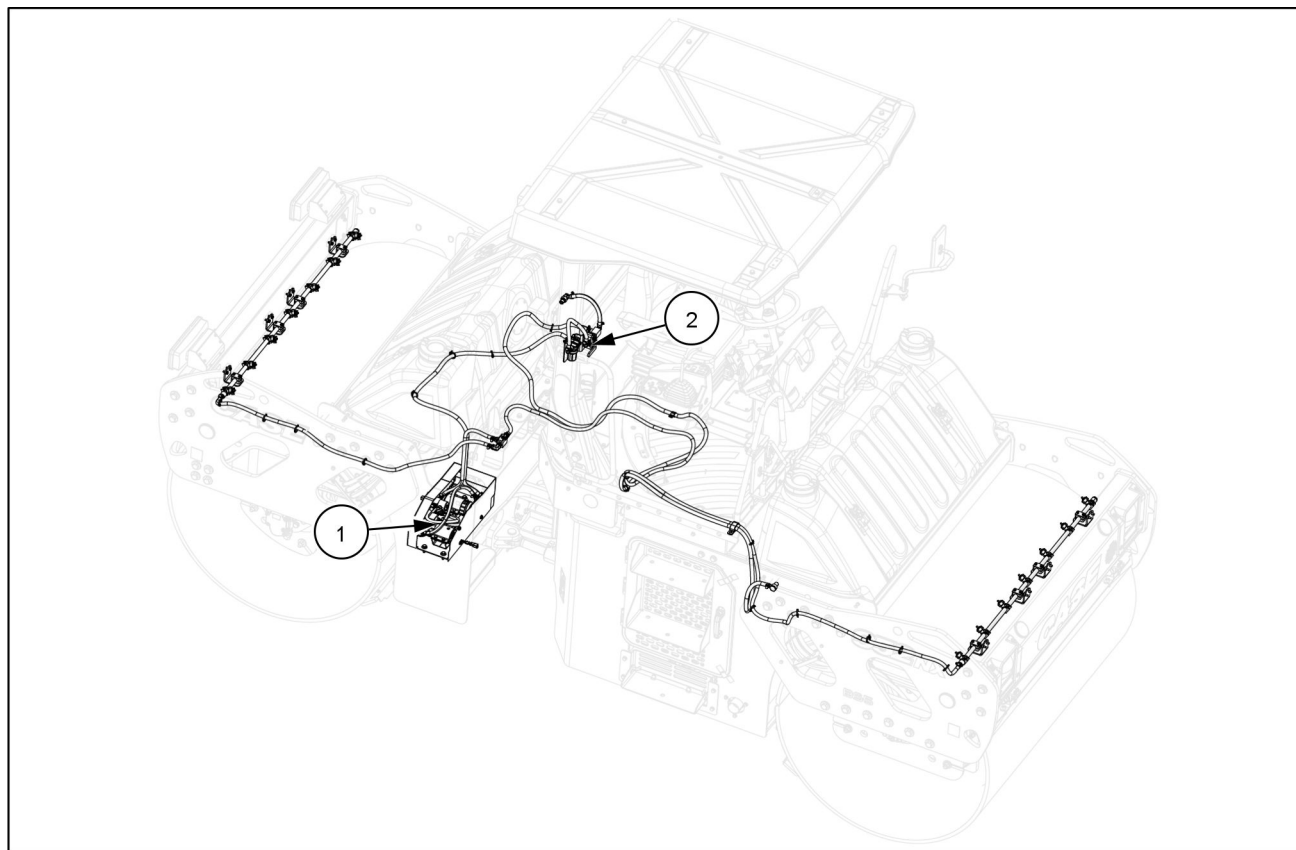

PTIL24COM1197FB 1

For such operation condition (temperature  $\leq 0$  °C), the pumps (1) must be completely drained when not in use. This will prevent freezing of water existing inside pumps (1) and will safeguard internal components of the pump. The pumps (1) can be drained by following steps:

1. Close the shut-off valve (2) as shown in the image 1.
2. Once the shut-off valve (2) is closed, switch on the pumps (1) and run till the internal water in the lines and the pumps (1) is completely drained through sprinkler jets.
3. Alternatively check the sprinkler jets carefully and wait till water dispensing is completely stopped.
4. Once the water is completely drained, switch off the pumps (1).
5. For the water pump screws tightening, see 7-24.

## Operating the machine

### **▲ WARNING**

**Hazard to bystanders!**

**Always sound the horn before starting the machine. Make sure the work area is clear of other persons, domestic animals, tools, etc. before you operate the machine. Never allow anyone in the work area during machine operation.**

**Failure to comply could result in death or serious injury.**

W0304A

### **▲ WARNING**

**Run-over hazard!**

**Only operate the machine when sitting in the operator's seat. Do not try to bypass the operator presence safety system by placing heavy objects on the seat.**

**Failure to comply could result in death or serious injury.**

W0318A

### **▲ WARNING**

**Roll-over hazard!**

**Observe the maximum permissible gradient when driving uphill and across the slope. The values given may be lower depending on traction conditions and the actual machine weight.**

**Failure to comply could result in death or serious injury.**

W1067A

**NOTICE:** It is not recommended to engage or change the vibration selection while the machine is moving. Damage to the machine hydraulic components may occur that will shorten the life of the components.

**NOTICE:** When driving for long distances, 1 h cooling breaks after 3 h of driving should be taken. Failing that, you are exposed to the risk of damage to the machine for which the manufacturer is not responsible.

1. Start the machine. Follow the starting procedure on 4-4.
2. Adjust the engine throttle control to the desired setting. Full throttle is recommended for working operations.
3. Confirm the travel speed switch is OFF.

**NOTE:** If the travel speed switch is ON you will not be able to engage vibration mode.

4. Disengage the parking brake switch.
5. Check that the area is clear and sound the horn before moving the machine.

**NOTE:** Engage the vibration selection before the machine starts to move and stop the machine before changing the vibration selection.

6. Select the desired vibration amplitude. High position - high frequency, low amplitude. Recommended for granular materials. Low position – low frequency, high amplitude. Recommended for cohesive materials.

**NOTE:** Press the vibration button on the travel controller to engage or disengage vibration mode.

7. Use the travel controller (FNR) lever to move the machine forward or reverse.
8. Always use caution when traveling across a slope. When possible always travel uphill or downhill but in some applications traveling across the slope is necessary so be aware.

**NOTE:** When master stop tell tale (red colour) glows on the cluster, the vehicle should be immediately shut down after moving to a safe stowing location. Contact CASE CONSTRUCTION service team for resolving issues on the vehicle.

**NOTE:** When master warning tell tale (amber colour) glows on the cluster, the vehicle should be moved to a safe stowing location. Issues should be corrected before using the vehicle to avoid any damage.

**NOTE:** Contact CASE CONSTRUCTION service team for resolving issues on the vehicle in case you are not able to resolve.

**NOTE:** Special care should be taken while cleaning the vehicle. No water washing to be done in engine chamber and electronic controllers to avoid damage. Clean with pressurised air instead.



## 7 - MAINTENANCE

### General information

### Preventive maintenance

Maintenance is the key to lower operating costs. A diesel engine requires regularly scheduled maintenance to keep it running efficiently. Maintenance is the key to lower operating costs. A diesel engine requires regularly scheduled maintenance to keep it running efficiently.

#### Maintenance schedule

Preventive maintenance is the easiest and least expensive type of maintenance. It permits the Maintenance Department to do the work at a convenient time.

#### A Good maintenance schedule depends on engine application

Actual operating environment of the engine governs the maintenance schedule. Some checks have to be performed more often under heavy dust or other special conditions.

The maintenance schedule check-sheet is designed as a guide until adequate experience is obtained to establish a schedule to meet a specific operation.

A maintenance schedule should be established using the check-sheet as a guide; the result will be a maintenance program to fit a specific operation.

### Engine inspection door - Open/Close

#### Opening the door

1. Insert the key to the lock plug (1).
2. Open the door (2) using the handle (3) to access the engine.
3. Repeat the steps 1 and 2 for other side.

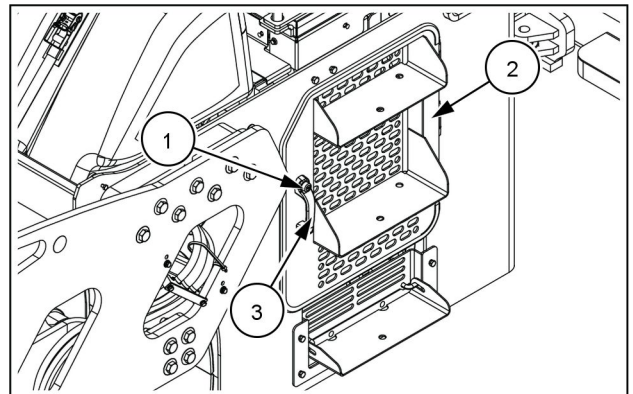

PTIL24COM1190AB 1

#### Closing the door

4. Close the door (1) using the handle (2).
5. Lock the door using the key in the lock plug (3)
6. Repeat the steps 4 and 5 for other side.

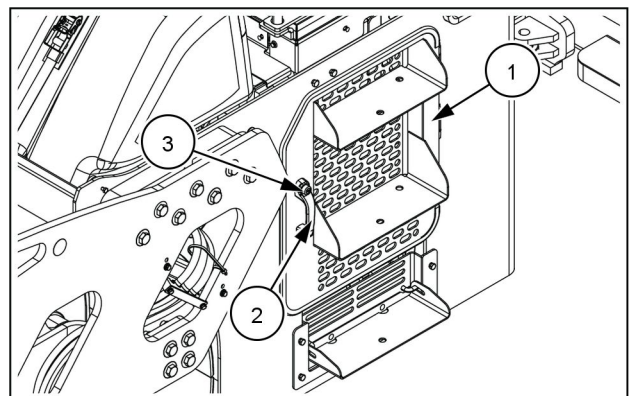

PTIL24COM1190AB 2

## Fuel tank

### ⚠ WARNING

#### Fire hazard!

When handling diesel fuel, observe the following precautions:

1. Do not smoke.
2. Never fill the tank when the engine is running.
3. Wipe up spilled fuel immediately.

Failure to comply could result in death or serious injury.

W0099A

The fuel tank (1) is located on the rear side of the machine, near the water tank. For capacity, see 7-3. Fill the fuel tank through the filler cap (2).

In cold weather, use a fuel suitable to the ambient temperature and refill at the end of each working day, in order to prevent condensation.

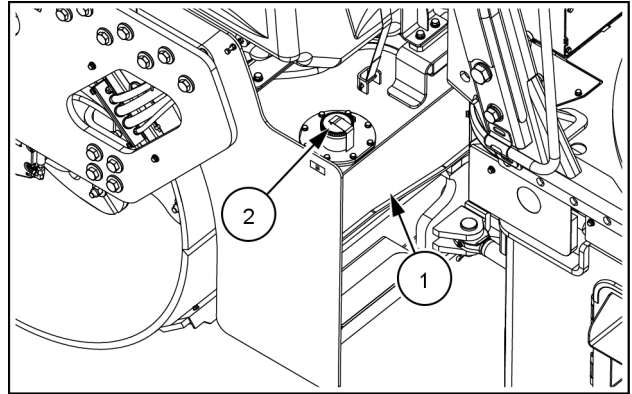

PTIL24COM1083AB 1

## Hydraulic oil tank

**NOTE:** For the most accurate hydraulic oil level check is when the hydraulic oil is cold or at ambient temperature.

The hydraulic oil tank (1) is located on the right-hand side of the machine, under the platform.

**NOTE:** Maximum fill cold level is a mid-level reading on the level indicator. For capacity see, 7-3.

Check the oil level through the level indicator (2).

Remove the floor plate (3) in operator platform to access the breather.

The hydraulic oil tank can be filled through the breather (4). The breather can be removed with a special wrench.

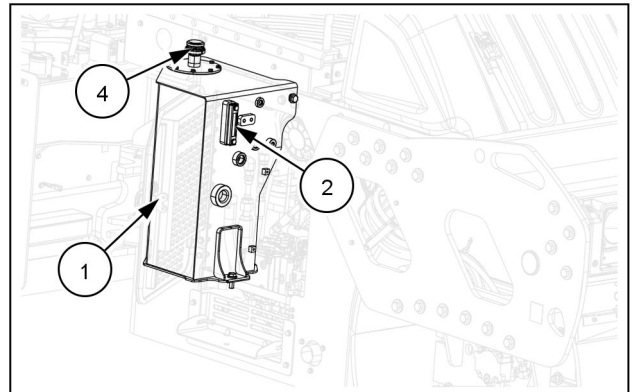

PTIL24COM1194AB 1

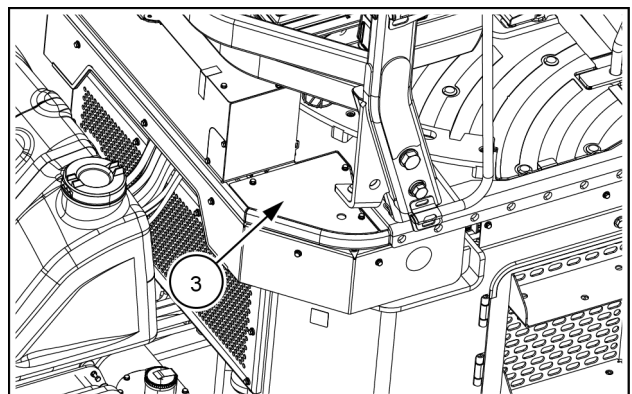

PTIL25COM0314AB 2

## Water tank

1. There are two water tank (1) in the machine, one is located on the front and another located on the rear.
2. Fill the water tank (1) through the filler cap (2).

**NOTE:** Water tank capacity, see 7-3.

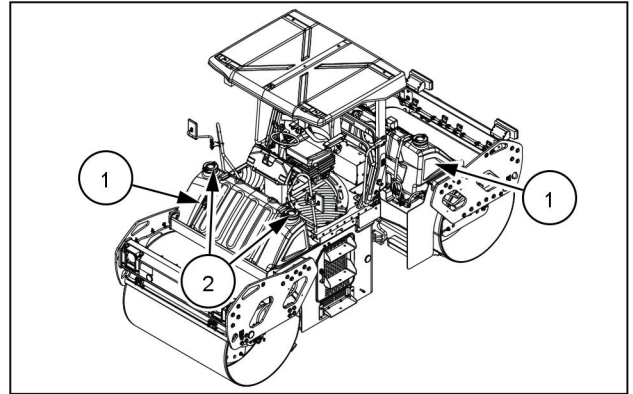

PTIL25COM0211AB 1

## Consumables

### ⚠ WARNING

**Chemical hazard!**

**Coolant can be toxic. Keep away from children and pets. Avoid prolonged contact. If not reused, dispose of in accordance with local environmental regulations.**

**Failure to comply could result in death or serious injury.**

W0295A

For the best protection of your investment, use the CASE CONSTRUCTION recommended lubrication and service products. Contact your dealer for these products and for any questions related to the machine's service and lubrication requirements.

Always remember the environment before you service the machine and before you dispose off the old fluids and lubricants.

You must follow local, state, and regional regulations when disposing of fluids, filters, fuels, and lubricants.

Do not put oil or fluid to the ground or in to containers that can leak.

Check with your local environmental or recycling center or your dealer for correct disposal information.

S.No.	Application	Capacity	Product name	Specification(s)
1	Grease	As required	<b>MULTI-PURPOSE GREASE EP / AW / NLGI 2</b>	Grease, Multi-Purpose NLGI 2
2	Engine oil	<b>8 L (Every 500 h)</b>	<b>No.1 ENGINE OIL™ SAE 10W-40 CK-4 SEMI-SYNTHETIC</b>	No.1 Engine Oil™ SAE 10W-40 CK-4 Semi-Synthetic
3	Engine coolant	<b>14 L (system volume and filled volume)</b>	Antifreeze, Grade OAT-EG2 50-50 Premix	Antifreeze, Grade OAT-EG2 50-50 Premix
4	Diesel - fuel	Tank capacity - <b>170 L</b>	Decanted and filtered diesel fuel	FUEL, DIESEL ULSD GRD 2D-S15
5	Hydraulic oil	System capacity - <b>118 L</b> Tank capacity - <b>70 L</b>	Non cold start (till <b>-5 °C</b> ) - OIL, HYD HM68	Non cold start (till <b>-5 °C</b> ) - OIL, HYD HM68
			Cold start ( <b>-6 °C to -15 °C</b> ) - OIL, HYD HV68	Cold start ( <b>-6 °C to -15 °C</b> ) - OIL, HYD HV68
6	Roller oil	<b>9.2 L</b>	<b>GEAR OIL SAE 80W-90, API GL 5, EXTREME PRESSURE (EP), LIMITED SLIP (LS)</b>	OIL, GEAR, 80W-90

S.No.	Application	Capacity	Product name	Specification(s)
7	Gear box oil	Front - 1.1 L Rear - 1.1 L	GEAR OIL SAE 80W-90, API GL 5, EXTREME PRESSURE (EP), LIMITED SLIP (LS)	HYPOID GEAR OIL, EP SAE 80W-90

# Ensure that the oil level on the dipstick is at the FULL mark after oil refill.

## Organic Acid Technology (OAT) coolant

CASE CONSTRUCTION recommends use of Organic Acid Technology (OAT) coolant solution that meets the specifications outlined in the CNH Industrial material specification **MAT3724**.

Use distilled or demineralized water for diluting when using coolant concentrate. The optimum coolant to water concentration is 50/50. This concentration will protect the cooling system to **-37 °C (-35 °F)**. Do not exceed **60%** by volume ethylene glycol-based coolant. The heat dissipation and antifreeze properties may otherwise be negatively affected. You can use a refractometer to check the concentration level. If distilled or demineralized water is not available, use water for dilution with the following properties:

Property	Limit Maximum
Total Solids	<b>340 ppm</b>
Total Hardness	<b>170 ppm</b>
Chloride (Cl)	<b>40 ppm</b>
Sulfate (SO4)	<b>100 ppm</b>
Acidity pH	5.5 to 9.0

**NOTICE:** NEVER mix OAT coolant with IAT coolant. Mixing of different coolant brands is not recommended. Under no circumstances should you top off a cooling system with only water. You should not use Supplemental Coolant Additives (SCA) when using **MAT3724** OAT coolant. Contact your CASE CONSTRUCTION dealer for approved additives and coolant analysis test package information.

### Service intervals

See 7-7 for the proper service intervals. Drain and flush the cooling system at the recommended service interval, then fill with fresh coolant.

### Definitions

Inorganic Acid Technology (OAT) coolant:

A coolant that relies on inorganic inhibitors such as silicates, nitrites, and phosphates for corrosion and cavitation protection.

Organic Acid Technology (OAT) coolant:

A coolant that relies on inhibitors such as organic acid salts for corrosion and cavitation protection.

## Engine oil temperature chart

CASE CONSTRUCTION prefers the use of engine oils that meet CNH Industrial standard **MAT3571** in your engine.

CASE CONSTRUCTION engine oils exceed API and ACEA performance requirements.

**NOTE:** Do not put performance additives or other oil additive products in the engine crankcase. Contact your CASE CONSTRUCTION dealer for approved engine oil additives, engine oil analysis test package information.

RECOMMENDED VISCOSITY GRADES AT VARYING AMBIENT TEMPERATURE LIMITS											
	(H)	SAE 0W-40									
		(H)	SAE 10W-40								
			(H)	SAE 10W-30							
				(H)	SAE 15W-40						
-40 °C	-30 °C	-20 °C	-10 °C	0 °C	10 °C	20 °C	30 °C	40 °C	50 °C		
-40 °F	-22 °F	-4 °F	14 °F	32 °F	50 °F	68 °F	86 °F	104 °F	122 °F		
(H) = Engine oil pan or coolant block heater recommended in this range											

## Engine oil and filter service intervals

CASE CONSTRUCTION develops the oil/filter change intervals given in this manual from tests with CASE CONSTRUCTION lubricants/filters.

Engine oil and filter service interval recommendations are based on type of engine oil, oil filter used, sulfur, bio-diesel content of diesel fuel. See diesel fuel recommendations for the approved Diesel fuel sulfur content, Bio-Diesel blends, and fuel specification information.

Always change engine oil and oil filter at the service intervals described in your maintenance chart. See 7-7.

## Diagnostic/Service tool port

### On board diagnostics

OBD system is a monitoring and detection system which can alert the component or system failures that can adversely affect emissions. Illuminates a dashboard light (Malfunction Indicator Lamp) to inform the driver of a fault. Provides standard and unrestricted access for diagnosis and repair.

- The vehicle is also fit with an ISO 11783 standard diagnostics connector.
- This connector allows the CNH Electronic Service Tool (EST) to be connected to the vehicle for off-board diagnostics and failure analysis.
- For On board diagnostics on Cluster LCD, use Arrow Switch provided below the Instrument Cluster.
- The image 1 shows the structure of an ISO 11783 plug.

Pin A	GND
Pin B	+ 12 V
Pin C	CAN 1 HI
Pin D	CAN 1 LO
Pin E	NC
Pin F	NC
Pin G	NC
Pin H	NC
Pin I	NC
Pin J	K LINE

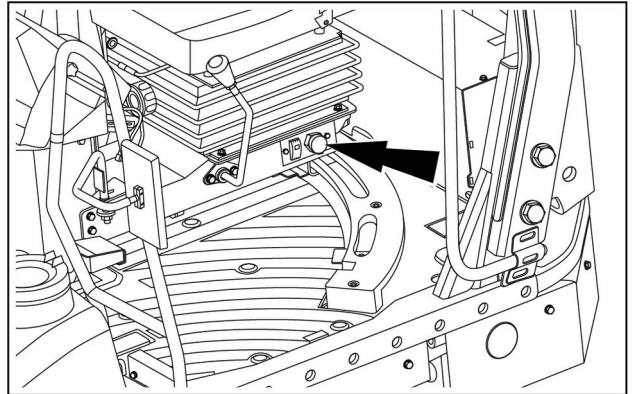
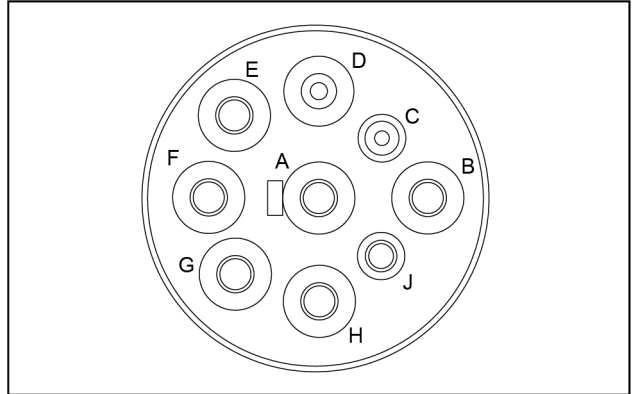

## Maintenance planning

## Maintenance chart

Maintenance action	Adjust				Cleaning				Page no.
	Drain fluid	Check	Grease	Tighten	Bleed	Change fluid	Replace		
								Adjust	
		Adjust	Clean						
At warning message display									
Water separator drain	x								7-9
Every 10 hours or daily									
Fuel tank level - Check		x							7-9
Engine parameter display - Check		x							7-10
Engine oil level and oil leakage - Check		x							7-10
Engine coolant level - Check		x							7-12
Hydraulic oil level - Check		x							7-12
Grease points - Lubricate			x						7-13
Air restriction / vacuum indicator - Check		x							7-14
Parking brake		x							7-14
Visual inspection		x							7-14
Functionality of controls and lamps		x							7-14
Water present in fuel filter - Check and Drain		x							7-15
Fan belt tension - Check		x							7-15
First 50 hours or 15 days									
Mounting bolts of Roller, Front and rear cross beam, Side plates - Check and tighten				x					7-18
Scrapper - Adjust					x				7-18
Operator platform, Canopy, Articulation joint mounting bolts - Check and tighten				x					7-19
Engine mounting bolts - Check and tighten				x					7-20
Every 100 hours or 20 days									
Hydraulic system breather - Cleaning					x				7-20
Engine, canopy and Operator platform mounting bolts - Check		x							7-21
Battery electrolyte level - Check		x							7-21
Battery terminals - Check and lubricate (if required)		x							7-22
Radiator and CAC hoses and clamps - Check and tighten (if required)		x							7-22
First 150 hours									
Travel Reduction gearbox oil - Replace						x			7-23
Every 250 hours or every 3 months									
Drain off water and deposits from the fuel tank		x							7-23
Every 500 hours or 6 months									
Water pump and its related mounting bracket bolts - Check and tighten				x					7-24
Hydraulic oil filter - Replace						x			7-24
Pre-filter - Replace						x			7-25
Fan mounting bolts - Check and tighten		x							7-25
Engine oil and oil filter - Change						x			7-26
Fuel filters - Replace						x			7-27
Radiator mounting bolts - Check and tighten		x							7-28
Battery cells voltage and specific gravity - Check		x							7-29
Radiator, HOC and CAC fins - Cleaning						x			7-29
Fuel strainer - Clean						x			7-30

7 - MAINTENANCE

Maintenance action	Adjust				Cleaning				Page no.	
	Tighten			x	Replace			x		
	Grease		x		Change fluid		x			
	Check	x			Bleed	x				
	Drain fluid				x					x
Baby filter - Replace					x			7-31		
Drain water from hydraulic tank	x							7-31		
Every 1000 hours or 12 months										
Exhaust pipe mounting - Check and tighten		x						7-32		
Cuts and Damage in Wiring harness – Check		x						7-32		
Drum oil - Replace						x		7-32		
Exhaust gas leakage check on all V band clamps		x						7-33		
Turbocharger mounting - Check		x						7-33		
Engine and cooling pack mounting rubber pad - Check and replace		x						7-33		
Travel Reduction gear box oil - Replace						x		7-34		
Every 1500 hours or 18 months										
Fuel hoses - Check and replace		x						7-35		
Fan belt - Replace						x		7-35		
Every 2000 hours										
Drum bearing - Grease			x					7-36		
Hydraulic oil - Replace							x	7-36		
Engine coolant - Replace						x		7-37		
Suction Strainer - Clean						x		7-38		
Every 4000 hours										
Diesel Oxidation Catalyst (DOC) assembly - Replace						x		7-39		
As required										
Water separator drain	x							7-39		
Engine air filter primary and secondary element - Replace						x		7-40		
Radiator, CAC - Cleaning whenever choked						x		7-41		
Fan / alternator belt - Replace		x						7-41		
Water sprinkling system - Cleaning						x		7-42		
Electrical systems - Check					x			7-42		
Bleed air from the fuel system							x	7-42		
ATS V-clamps and gaskets - Replace						x		7-42		
Fuel strainer - Clean						x		7-43		

## At warning message display

### Water separator drain

**NOTICE:** Fuel leakage contaminates the environment. When working on the filter, place a collecting vessel below the engine and dispose of collected fuel properly.

1. It is necessary to drain the collected water if the water collecting vessel is full and when the spin-on filter has been changed.
2. Undo drain plug (1) and allow the water to drain off.
3. Re-tighten the drain plug (1).

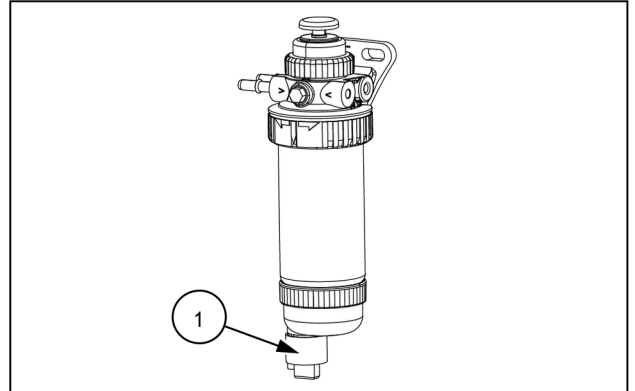

PTIL24COM1085AB 1

## Every 10 hours or daily

### Fuel tank level - Check

#### **▲ WARNING**

Fuel vapors are explosive and flammable.

Do not smoke while handling fuel. Keep fuel away from flames or sparks. Shut off engine and remove key before servicing. Always work in a well-ventilated area. Clean up spilled fuel immediately. Failure to comply could result in death or serious injury.

W0904A

When handling fuel, follow all safety precautions listed below:

- Fuel may be irritant on skin; wear gloves or apply some protective cream.
- Never remove the plug or refill with the engine running.
- Before filling the tank, clean the area around the filler plug in order to prevent that foreign bodies enter the tank. After filling, screw in and tighten the plug again.
- Do not spill fuel and do not let it be absorbed by the ground, as it represents a danger of environmental pollution.
- Immediately absorb fuel spill overs with rags or binding substances, then dispose of them according to the environmental legislation.

1. Move the machine to a level and firm ground.
2. Place the direction-of-travel lever in neutral position.
3. Immobilize the machine with the parking brake.
4. Stop the engine and remove the starter switch key.
5. Wait for the machine to cool down.
6. Again insert the key in ignition switch and rotate it.
7. Check the relevant gauge **(1)** in the side instrument panel.
8. If necessary, top up.

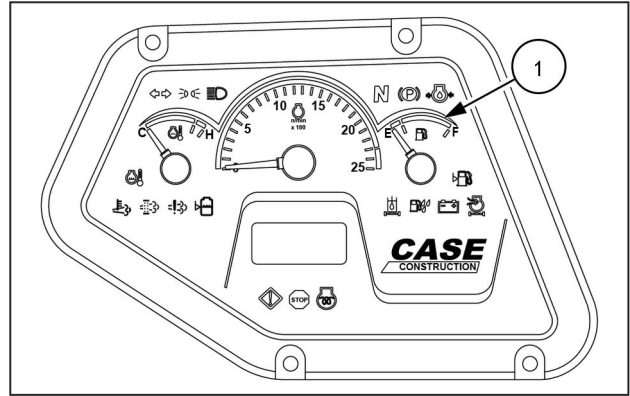

PTIL25COM0274AB 1

### Fuel specification and capacity:

Use decanted and filtered Ultra Low Sulfur Diesel (ULSD) fuel only.

**NOTE:** The sulfur content should not exceed 10 mg/kg.

For fuel specification and tank capacity, see 7-3.

### Engine parameter display - Check

Check the engine parameters engine oil pressure, engine coolant temperature, engine coolant temperature gauge on the instrument cluster, see 3-12.

### Engine oil level and oil leakage - Check

#### Engine oil level check

1. Move the machine to a level and firm ground.
2. Before checking the oil level, ensure that the equipment is standing on a level ground. Also allow **10 min** or warm oil to settle down in the sump.
3. Remove the front grill **(1)** from the chassis frame.

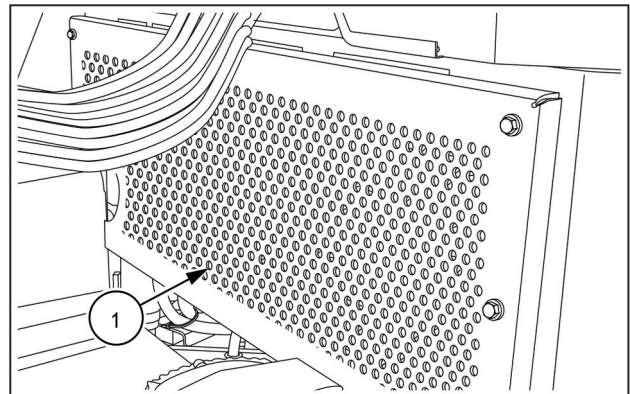

PTIL25COM0307AB 1

4. Withdraw the dipstick (2) from the tube located on the LH side of engine.
5. Note the level on the scale and top up as necessary with new oil to recommended specification.
6. With a clean piece of cloth wipe the dipstick scale and re insert fully.

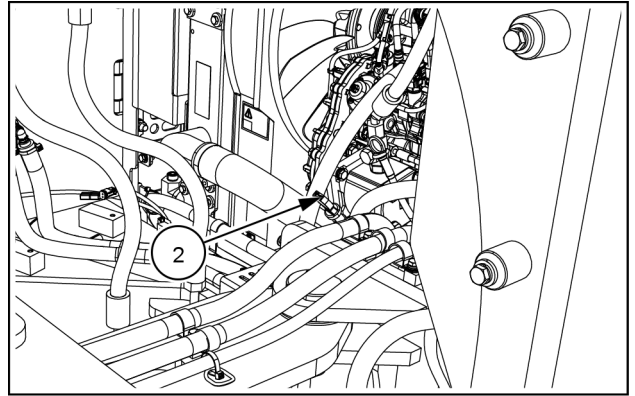

PTIL25COM0312AB 2

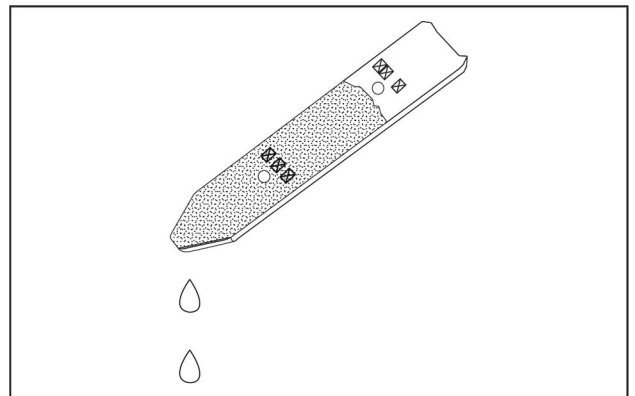

PTIL21COM0739AB 3

### Engine oil leakage check

7. Check the engine for oil leakage.
8. If any oil leakage found at the engine hoses, tighten the hoses clamps to specified torque.
9. If any oil leakage found at the drain port, tighten the drain plug (3) to the torque **45 – 55 N·m**.
10. If any oil leakage found due to overflow, drain the oil and make sure that the engine oil level is filled to the standard mark.

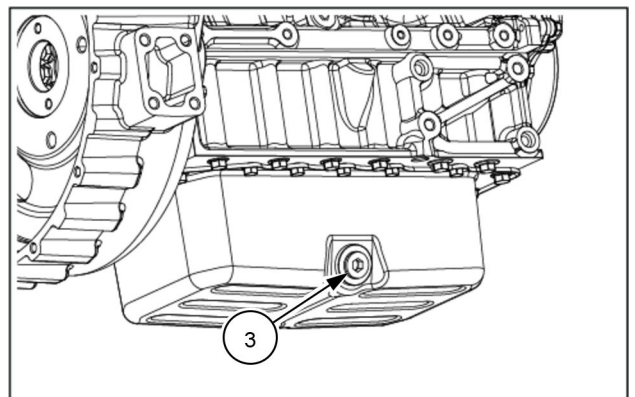

PTIL24TLB0321AB 4

## Engine coolant level - Check

### ⚠ CAUTION

#### Burn hazard!

Take care if removing the filler cap while the system is hot. Before removing the cap: completely cover the cap using a thick cloth, and slowly open the filler cap to allow the pressure to escape. Do not add cold water to a hot coolant reservoir.

Failure to comply could result in minor or moderate injury.

C0031A

1. Move the machine to a level and firm ground.
2. Place the FNR lever (or transmission lever) in neutral position.
3. Immobilize the machine by means of the parking brake.
4. Stop the engine and remove the starter key.
5. Wait for the machine to cool down.
6. Check the fluid level in the coolant reservoir (1) through window.
7. The level in the coolant reservoir (1) must be between the maximum and minimum marks on reservoir.
8. If the fluid level is low, refill the fluid.
9. Open the cover located left-hand side door to access the coolant reservoir (1).
10. Once the maximum level reached, stop and close the cap (2).

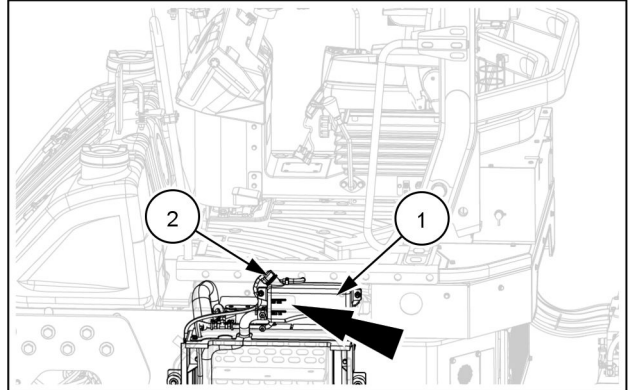

PTIL25COM0294AB 1

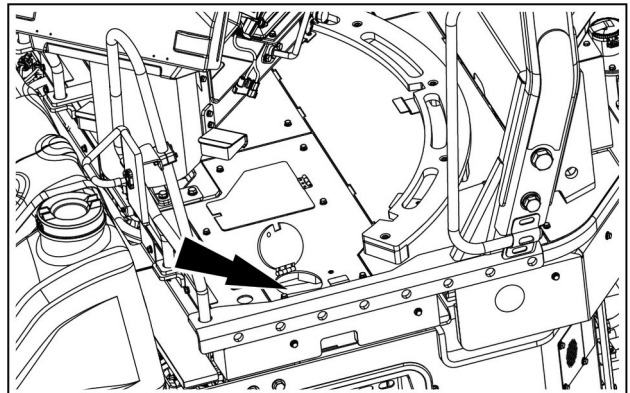

PTIL25COM0303AB 2

## Hydraulic oil level - Check

1. Park the machine on a level ground.
2. Release any possible residual pressure from the hydraulic system by moving the control levers in all directions.
3. Check the hydraulic oil level in the tank (1) by means of the level gauge (2) after waiting for the oil to reach the ambient temperature.
4. The hydraulic oil level must reach at least the half of the gauge (2).
5. If necessary, open the cap (3) and top up with the specified oil. See 7-3.

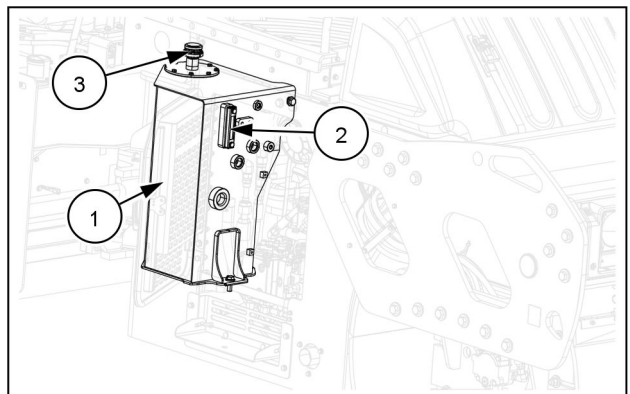

PTIL24COM1194AB 1

**NOTE:** Even when its level is insufficient, a small quantity of hydraulic oil remains in the lower part of the gauge. This does not mean that the level is sufficient.

## Grease points - Lubricate

1. Remove the caps from the grease nipples.
2. Successively mount the grease nipple of pressure lubricator and continue greasing until the old grease starts to drain out.
3. Return the grease nipple caps.

### Roller drum bearing

- Bearing grease fitting (four places)

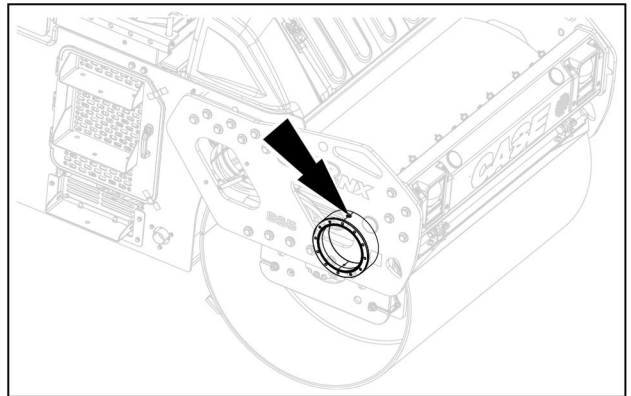

PTIL25COM0295AB 1

### Articulation joint

- Articulation joint pin (two places)

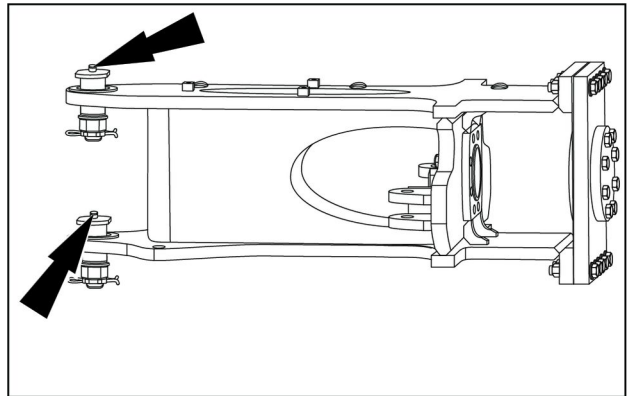

PTIL24COM1219AB 2

### Articulation steering cylinder

- Cylinder grease fitting (four places)

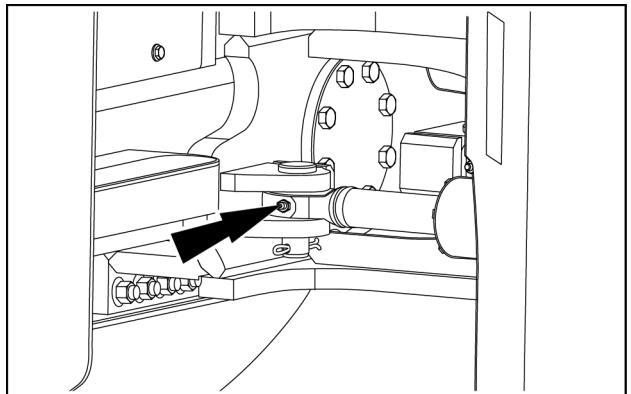

PTIL24COM1227AB 3

## Air restriction / vacuum indicator - Check

1. Check the air restriction indicator on the instrument cluster for any sound alarms or warning lamp.

**NOTE:** This indicator turns red when there is any clog.

2. Clean or replace the primary filter and/or replace the secondary filter when this lamp illuminates.

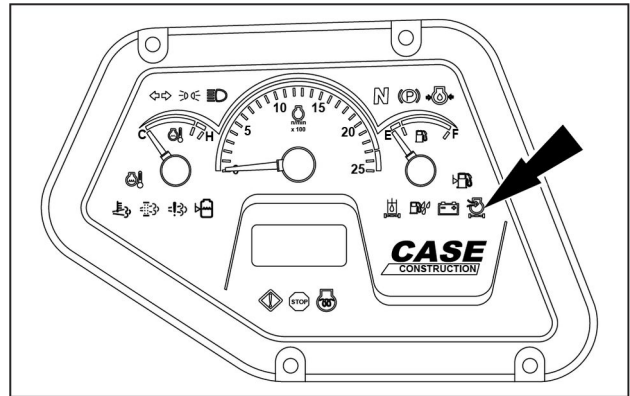

PTIL25COM0274AB 1

## Parking brake

The parking brake is not serviceable. If a reduction of the braking action is detected, contact your CASE CONSTRUCTION dealer.

## Visual inspection

1. Remove any residues of material immediately after working on asphalt. Check the machine visually for contamination and clean, if necessary.
2. Retighten the screws and bolts, if necessary. If the machine is in standstill for a long period, check all functions at regular intervals.  
Visually inspect the machine for :-
  - a. Cracks on important components and welds.
  - b. Condition of elastic suspensions.
  - c. Leakages for fuel, engine oil, hydraulic oil, air intake system.

## Functionality of controls and lamps

Before using the machine, it is recommended to check that all controls, instruments and lamps in the operator's compartment are correctly operating.

## Water present in fuel filter - Check and Drain

1. Loosen the bleed screw (1) and check for water present in the fuel filter (2).
2. If water present in the filter, drain the water.

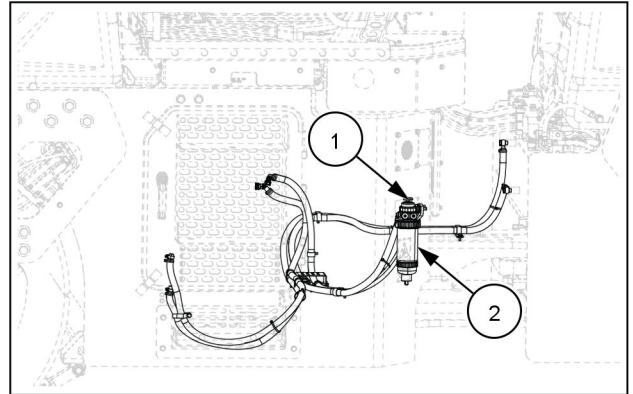

PTIL25COM0256JB 1

## Fan belt tension - Check

**NOTE:** Check the fan belt tension and condition and adjust/replace only if required.

1. Move the machine to a level and firm ground.
2. Make sure that the FNR lever is in neutral position.
3. Engage the parking brake.
4. Stop the engine and remove the key.

### Drive Belt - Check

5. Visually check that the alternator belt is not worn or damaged; if it is replace.
6. Wait at least **15 min** with the engine idling, then with the engine off and the temperature of the belt at stabilised at  $23 \pm 5 \text{ }^\circ\text{C}$  use a suitable tool to check the tension of the drive belt, The correct tension value of the drive belt (2) must lie within the interval indicated in the table.

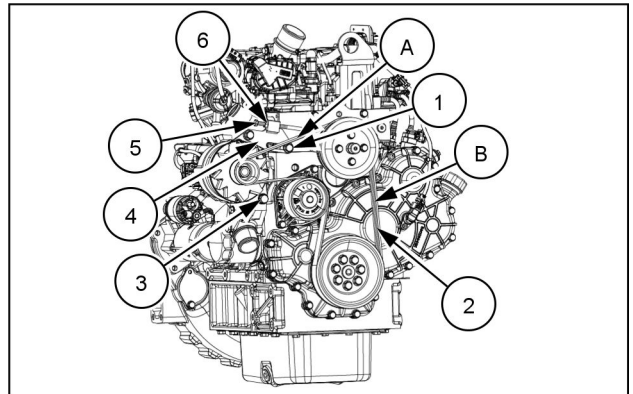

PTIL25TLB0128AB 1

### Ancillary belt tension

Control frequency (A) ( $140 \pm 20 \text{ N/rib}$ )	Control frequency (B) ( $140 \pm 20 \text{ N/rib}$ )
$190 \pm 14 \text{ Hz}$	$151 \pm 11 \text{ Hz}$

**NOTE:** : The belt tension is measured in the intermediate point (B) of the branch between the crankshaft pulley and the fan drive pulley and in point (A) between the alternator pulley and the fan drive pulley. Use the designated tool to check the correct belt tension.

7. If necessary, adjust the belt tension (2) as described below.
8. Loosen the bolt (3) anchoring the alternator to its lower mount and the screw (5) fastening the tensioning bracket to the crankcase.

9. Tension the drive belt (2) by tightening the adjusting screw (5) until the tensioning bracket (4) reaches the maximum extension position of the available adjustment, as shown in the figure.
10. Make the crankshaft perform two complete rotations to settle the drive belt (2).
11. Tighten the screw (1) fastening the tensioning bracket (4) to the crankcase to the prescribed torque.

Description	Step	Value
Alternator tensioning bracket	2 screws M10 X 1.5 x 25 +2 nuts M10 X 1.5	50 ± 5 N·m

12. Tighten the bolt (3) anchoring the alternator to its lower mount to the prescribed torque.

Description	Step	Value
Alternator	1 screw M10 X 1.5 x 130 + 1 nut M10 X 1.5	50 ± 5 N·m

13. Turn the adjusting screw (5) two complete revolutions anticlockwise, then tighten the relative lock nut (6) to the prescribed torque.

Description	Step	Value
Belt tensioning screw	1 screw M8 X 1.25	20.5 ± 2.5 N·m
	1 nut M8 X 1.25	20.5 ± 2.5 N·m

**Belt - Replace**

14. Loosen the bolt (3) anchoring the alternator to its lower mount and the screw (2) fastening the tensioning bracket (4) to the crankcase.
15. Loosen the lock nut (6) and unscrew the adjusting screw (5) on the tensioning bracket (4) to loosen and remove the drive belt (1)
16. Replace the drive belt (1) with a new one
17. Make sure that all the components of the pulleys and the guide rollers are clean and free of wear and damage. If necessary, replace the worn or damaged components
18. Make sure that the pulleys and guide rollers are free of dirt and accumulation of the old belt.
19. Fit the new drive belt (1) inside the shoulders of all the pulleys, in the following order: crankshaft pulley, fan control pulley, alternator, water pump. Make sure that the belt is centred on all pulleys.

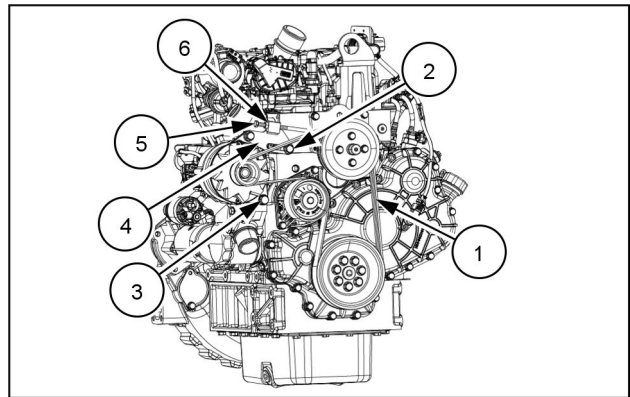

PTIL25TLB0128AB 2

**NOTE:** The ribs on the drive belt (1) must be positioned in the grooves of each pulley

20. Tension the drive belt (1) by tightening the adjusting screw (5) until the tensioning bracket (4) reaches the maximum extension position of the available adjustment, as shown in the figure.

**NOTE:** The belt tension is measured as described in the procedure DRIVE BELT using the designated tool.

21. Make the crankshaft perform two complete rotations to settle the drive belt (1).

22. Tighten the screw **(2)** fastening the tensioning bracket **(4)** to the crankcase to the prescribed torque.

Description	Step	Value
Alternator	1 screw M10 X 1.5 x 130 + 1 nut M10 X 1.5	$50 \pm 5 \text{ N}\cdot\text{m}$

23. Tighten the bolt **(3)** anchoring the alternator to its lower mount to the prescribed torque.

Description	Step	Value
Alternator	1 screw M10 X 1.5 x 130 + 1 nut M10 X 1.5	$50 \pm 5 \text{ N}\cdot\text{m}$

24. Turn the adjusting screw **(5)** two complete revolutions anticlockwise, then tighten the relative lock nut **(6)** to the prescribed torque.

Description	Step	Value
Belt tensioning screw	1 screw M8 X 1.25	$20.5 \pm 2.5 \text{ N}\cdot\text{m}$
	1 nut M8 X 1.25	$20.5 \pm 2.5 \text{ N}\cdot\text{m}$

**First 50 hours or 15 days**

**Mounting bolts of Roller, Front and rear cross beam, Side plates - Check and tighten**

1. Check the tightness of all the bolts of the roller mounting , cross beam and side plates.
2. Tighten the bolts (1), (2) and (3) to a recommended torque value.  
 Side plates (1) -  $915 \pm 5 \% \text{ N}\cdot\text{m}$   
 Cross beam (2) -  $690 \pm 10 \% \text{ N}\cdot\text{m}$   
 Roller mounting (3) -  $690 \pm 10 \% \text{ N}\cdot\text{m}$

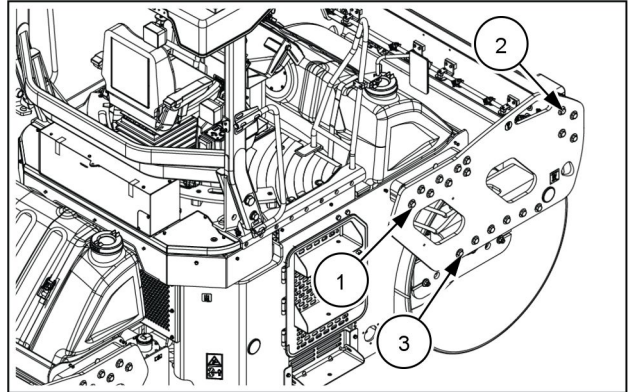

PTIL25COM0311AB 1

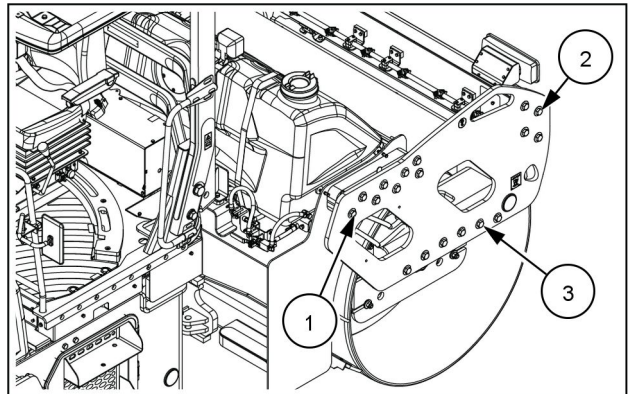

PTIL25COM0292AB 2

**Scraper - Adjust**

To remove the asphalt and other particles from the surface of the drums four scrapers are provided.

1. Two scrapers are mounted on front roller frame at front and rear of front roller drum and two are mounted on rear chassis frame at front and rear of the rear drum.
2. Check and if required, tighten the scraper mounting bolts.
3. Check the scraper for wear, adjust if required and replace if necessary.

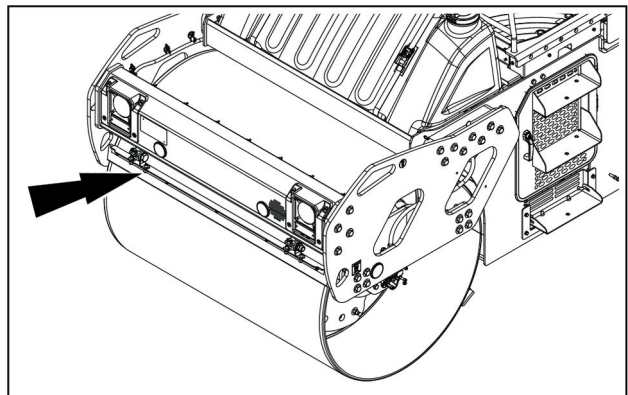

PTIL25COM0308AB 1

## Operator platform, Canopy, Articulation joint mounting bolts - Check and tighten

1. Check the tightness of the operator platform mounting bolts (1) at the front and rear of the machine.
2. Tighten the bolts (1) along with nuts (2) and washers (3) to torque value of **120 – 160 N·m**.

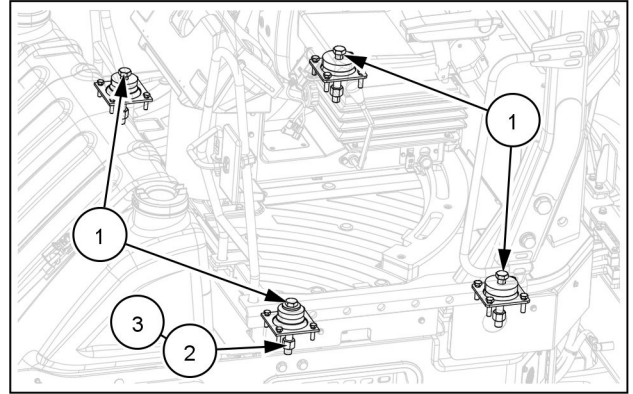

PTIL25COM0255JB 1

3. Check the tightness of the canopy mounting bolts (4) and (5) both the sides of the machine.
4. Tighten the bolts (4) along with nuts and washers to torque value of **980 – 1078 N·m**.
5. Tighten the bolts (4) along with nuts and washers to torque value of **690 – 760 N·m**.

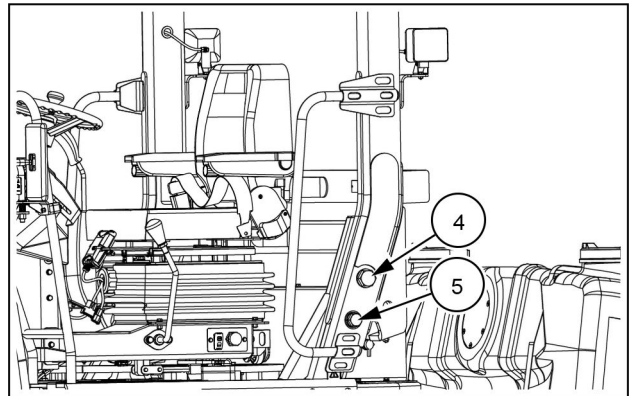

PTIL24COM1239AB 2

6. Check the tightness of the articulation joint mounting bolts (6) of the machine.
7. Tighten the bolts (4) along with nuts and washers to torque value of **225.1 – 304.6 N·m**.

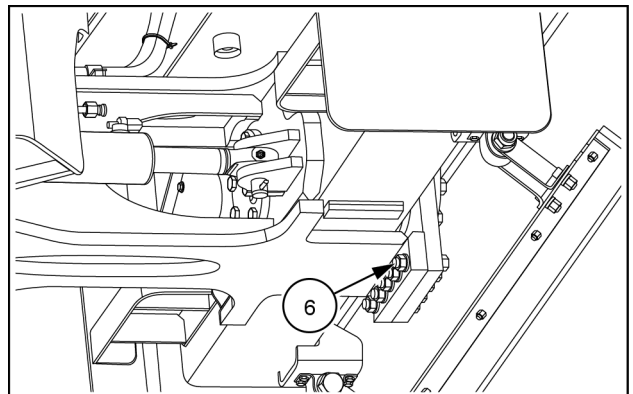

PTIL24COM1238AB 3

## Engine mounting bolts - Check and tighten

1. Check the tightness of the engine mounting bolts (1) along with washers.

**NOTE:** Always replace washers whenever bolts are replaced.

2. Torque the bolts (1) along with nuts and washers to a torque value of **178 – 240 N·m**.
3. Torque the bolts (2) along with nuts and washers to a torque value of **130 – 135 N·m**.
4. Periodically check the mount and make sure that there are no cracks. Measure crack depth with a straight edge.

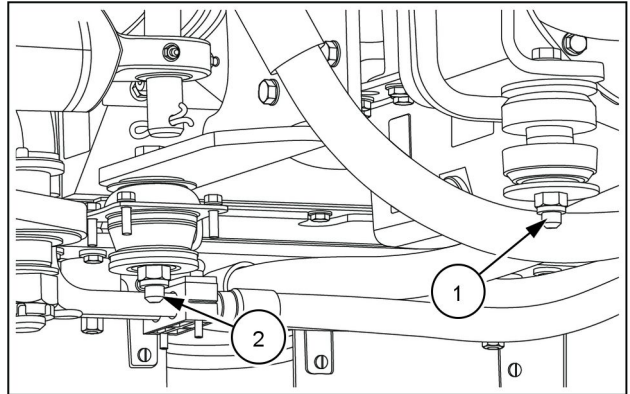

PTIL25COM0309AB 1

Every 100 hours or 20 days

## Hydraulic system breather - Cleaning

1. Check the hydraulic oil tank breather (1) cum filler cap for contamination.
2. If there is any dirt / dusts, clean the hydraulic oil tank breather (1) cum filler cap.

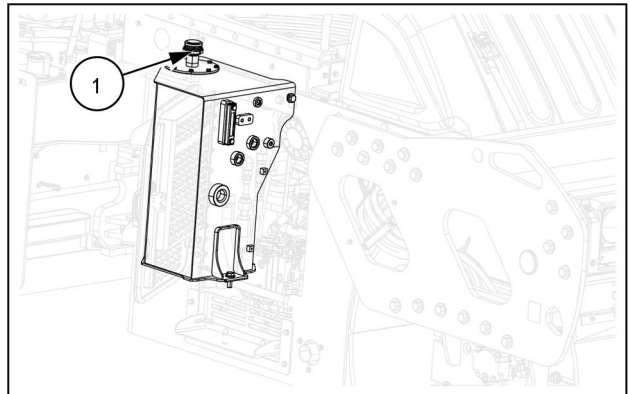

PTIL24COM1194AB 1

---

## Engine, canopy and Operator platform mounting bolts - Check

1. For checking engine mounting bolts, see **7-20**.
2. For checking Operator platform, Canopy, mounting bolts, see **7-19**.

## Battery electrolyte level - Check

1. Remove the battery caps and check the Specific Gravity of each cell, with a hydrometer.
2. Normally Specific gravity readings at **27 °C** (Fully charged) will be 1.270/1.290. For other temperatures above **27 °C** add 0.007, and below **27 °C** subtract 0.007 for every **10 °C**.
3. Electrolyte level must always be maintained between the "Max" and "Min" line as shown on the battery, see image 1. In case of any drop-in level add distilled water. Never add acid.
4. Check and apply petroleum jelly to battery terminals, never apply grease.
5. The Alternator charging voltage setting measured across the battery terminals must be maintained at **13.8 – 14.2 V** for **12 V** system.

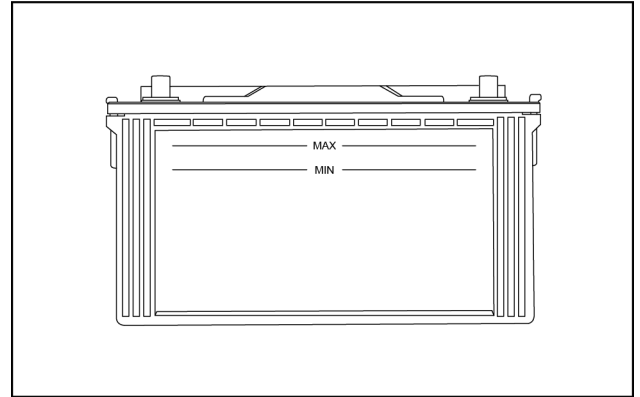

PTIL21COM0920AB 1

## Battery terminals - Check and lubricate (if required)

### ⚠ DANGER

Battery acid causes burns. Batteries contain sulfuric acid.

Avoid contact with skin, eyes or clothing. Antidote (external): Flush with water. Antidote (eyes): flush with water for 15 minutes and seek medical attention immediately. Antidote (internal): Drink large quantities of water or milk. Do not induce vomiting. Seek medical attention immediately.

Failure to comply will result in death or serious injury.

D0117A

1. The battery is located in the battery compartment behind the operators seat.
2. Rotate the battery cut OFF switch (1).
3. Check the battery terminals (2).
4. If required, clean the battery terminals (2).
5. Apply petroleum jelly on battery terminals before clamping negative cable.

**NOTE:** Never apply grease.

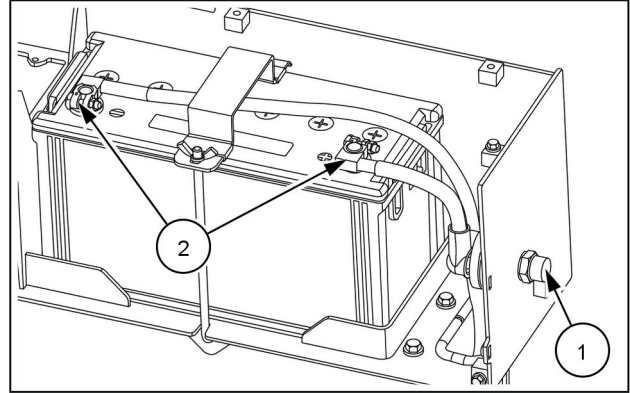

PTIL24COM1237AB 1

## Radiator and CAC hoses and clamps - Check and tighten (if required)

1. Check radiator (1) and charge air cooler hoses (2) and clamps (3) for leakages and tightness.
2. If the hoses (2) and clamps (3) are not tight and are prone to leakages, replace them with new hoses (2) and clamps (3) and tighten to a torque value 14 N·m.
3. The cooling pack fin cleanliness condition should be regularly checked to clear with pressurised air to avoid any heating issues.

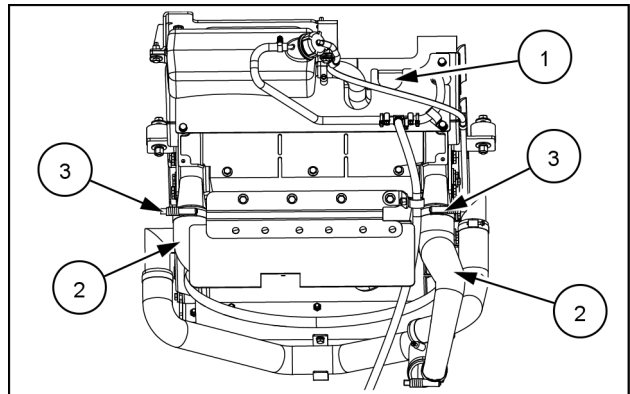

PTIL24COM1090AB 1

## First 150 hours

### Travel Reduction gearbox oil - Replace

1. Move the machine to a level firm ground.
2. Make sure that the FNR lever is in neutral position.
3. Engage the parking brake.
4. Stop the engine and remove the key.
5. Place a container below the gear box.
6. Unscrew the oil drain plug **(1)**, drain the oil and re-tighten the oil drain plug **(1)**.
7. Unscrew the oil level plug **(2)** and oil filler plug **(3)**.
8. Refill the gear box with clean oil through oil filler plug **(3)** until the oil starts to over-flow out of oil level plug **(2)**.

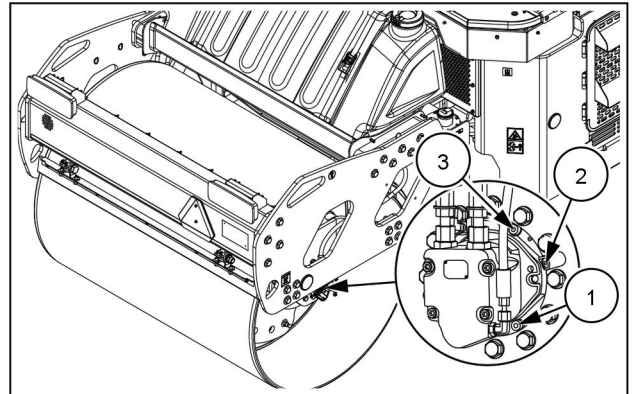

PTIL24COM1236AB 1

**NOTE:** See 7-3 for oil specification and quantity.

9. Re-tighten the plugs on oil filler plug **(3)**.

**NOTE:** Tighten all the three oil plugs **(1)**, **(2)**, & **(3)** to a torque of  $15\pm 3$  N·m.

## Every 250 hours or every 3 months

### Drain off water and deposits from the fuel tank

1. Drain the sediments/ water from the fuel tank by loosening the drain plug **(1)** provided at the bottom of the tank by few threads.
2. Retighten the drain plug **(1)** after the fuel starts flowing out.

**NOTICE:** Keep the fuel tank filled when machine is to be stowed away to avoid rusting in tank.

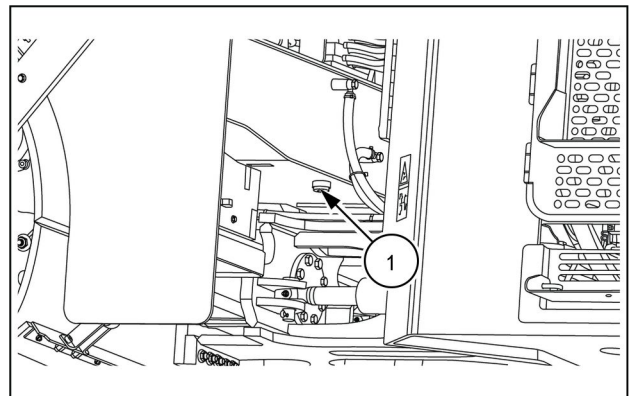

PTIL24COM1210AB 1

Every 500 hours or 6 months

## Water pump and its related mounting bracket bolts - Check and tighten

1. Check the tightness of the water pump bolts (1).
2. If the bolts (1) found loose, then tighten the bolts (1) for torque value see 9-6.
3. For water pump safety measures in cold regions, see 6-4.

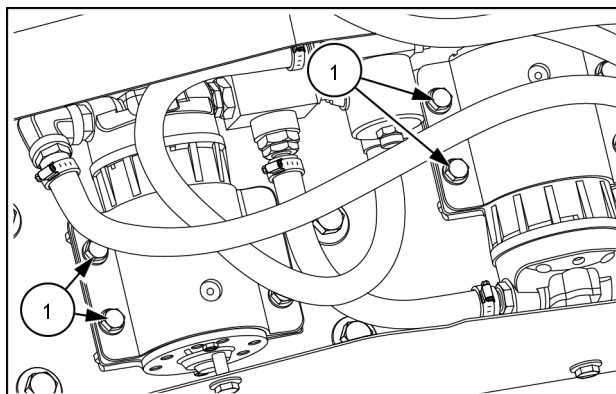

PTIL24COM1211AB 1

## Hydraulic oil filter - Replace

1. The hydraulic oil filter (1) provided on this machine is a medium pressure filter equipped with a hydraulic oil clog sensor.
2. There is a hydraulic oil filter clog indicator provided on the control panel which glows whenever the filter element clogs.
3. Open the right-hand side engine compartment door to access the hydraulic oil filter (1).
4. To change the hydraulic filter element, loosen the filter cover from filter assembly and remove it together with the filter element.
5. Check the seal rings below the filter cover and replace them if necessary.
6. Install new filter element and refit the cover.

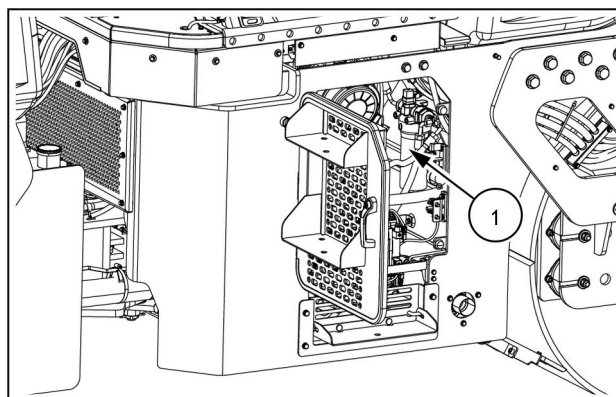

PTIL24COM1233AB 1

**NOTE:** Use only specified and genuine hydraulic oil filter.

## Pre-filter - Replace

1. Follow machine safety position, see 2-1 and **Safety rules**.
2. Disconnect the inlet and outlet hoses from fuel pre-filter (1).
3. Drain the water and/or contaminants from the pre-filter into a suitable container until clean fuel flows.
4. Turn the pre-filter counterclockwise to remove it.
5. Replace with a new pre-filter cartridge, turning clockwise until the cartridge meets the pre-filter head.
6. While replacing pre-filter unit, ensure make sure that all clamps and cable ties are installed and routed as shown in image 1.

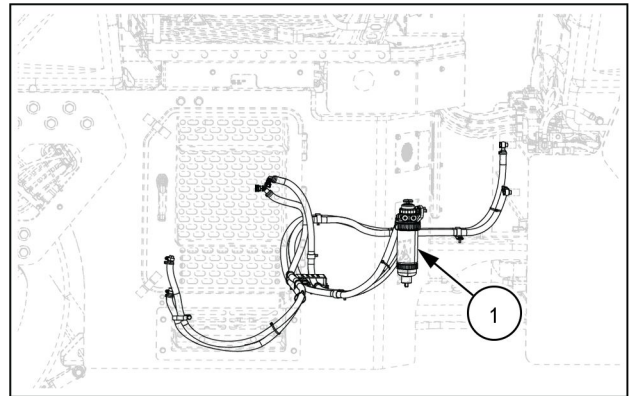

PTIL25COM0256JB 1

## Fan mounting bolts - Check and tighten

1. Check for the tightness of bolts (1) of the fan mounted on the engine.
2. If the bolts (1) are not tight retighten the bolts (1) to the torque value of **20 – 25 N·m**.

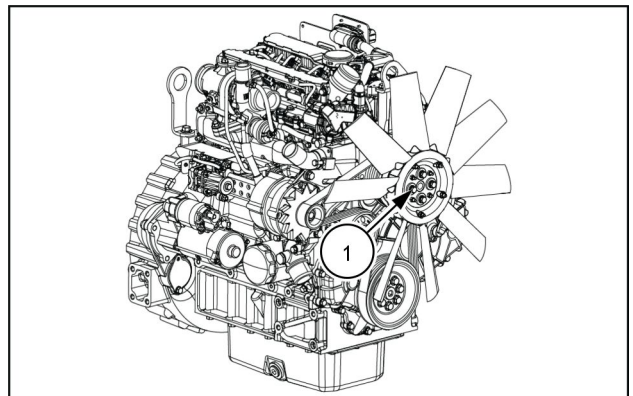

PTIL24TLB0322AB 1

## Engine oil and oil filter - Change

### Draining the oil

1. Follow machine safety position. See **2-2**.
2. Place the suitable container below the machine to collect the drain oil.
3. Remove the engine drain plug **(1)** at the bottom.

**NOTE:** Drain the engine oil when it is still hot. The oil will flow more easily.

4. Now wait for the oil to completely flow out of the engine.
5. Draining of oil should be started within **10 min**, from shutdown. After positioning a suitable drain tray under the sump remove the drain plug and drain the oil.

6. Tighten the drain plug **(1)**.

7. Refill the new engine oil as shown in steps **16** to **19**.

**NOTE:** After refill the oil make sure the oil level is at "FULL" mark.

8. Close and tighten the filler cap.

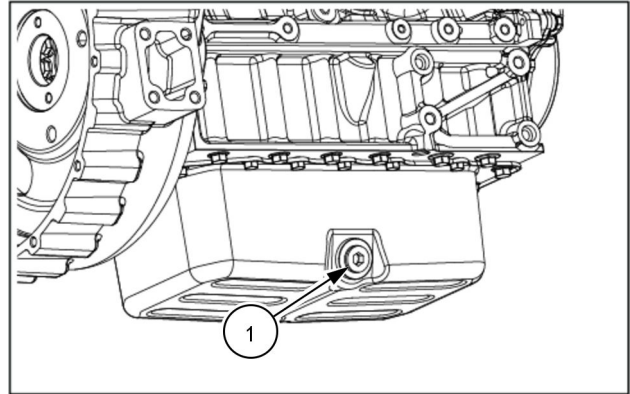

PTIL24TLB0321AB 1

### Engine Oil Filter Cartridge - Replace

9. Position a suitable container to collect the exhaust oil under the filter bracket.
10. Use the special tool to unscrew and remove the oil filter **(2)** from the filter bracket and recover the gasket **(3)**.

11. Replace the oil filter **(2)** and the gasket **(3)**.

12. Moisten the sealing gasket **(3)** with a thin layer of oil and place it in its seat on the oil filter **(2)**.

13. Tighten the oil filter **(2)** manually on the bracket until the sealing gasket **(3)** adheres.

14. Use the special tool to further tighten the oil filter **(2)** to torque.

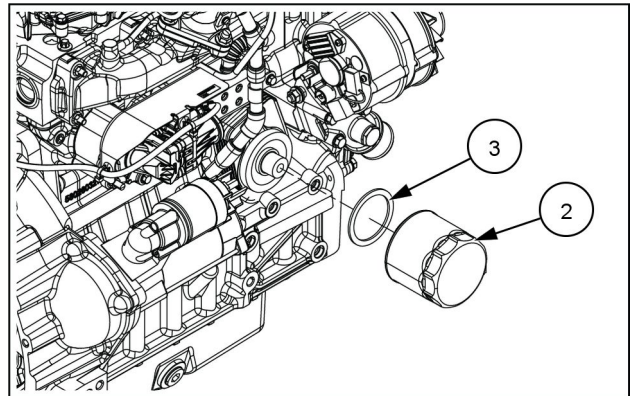

PTIL25TLB0127AB 2

Description	Quantity	Value
Oil filter	1 cartridge M27 X 2	<b>18 ± 2.5 N·m</b>

15. Run the engine for a few minutes and then check the level using the dipstick. If necessary, top up to compensate for the oil quantity used to fill the filter cartridge.

## Replacing the engine oil

- Remove the filler cap (4) and fill oil up to the "Max" mark on the dipstick. See 7-3 for correct oil grade.

**NOTE:** Engine oil can be filled with funnel after opening the oil filler cover.

- Retighten the filler cap (4).
- Start the engine and let it run for **10 min** and then check the level again by means of the dipstick.
- If necessary, top up to compensate the quantity of oil used for filling the cartridge.

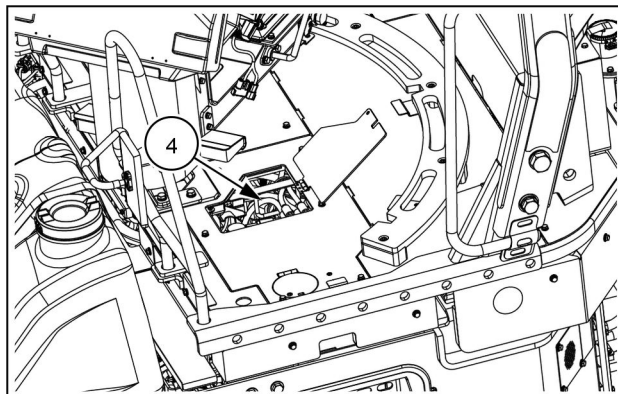

PTIL24COM1231AB 3

## Fuel filters - Replace

- Follow machine safety position. See 2-2.
- Clean the filter (1) assembly externally.
- Remove the fuel filters (1) and discard.
- Clean the filter (1) mounting surface.

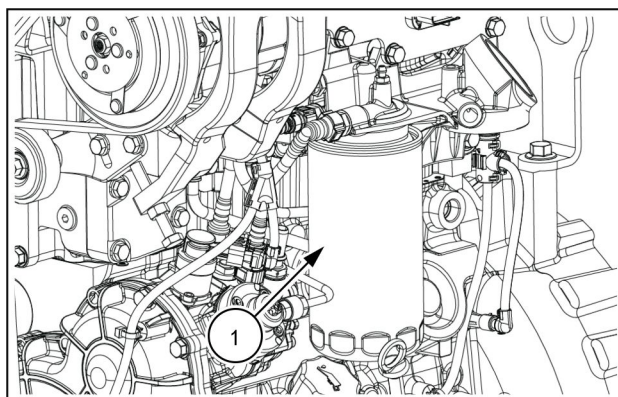

PTIL24TLB0329AB 1

## Renewal procedure for fuel filter

**NOTE:** Do not use grease. The use of grease can result in Fuel leakage between the sealing gasket and the fuel filter head.

**NOTE:** Ensure crimp part of fuel hoses should not foul with filter body after assembly.

- Pre-fill the new filter (1) with clean fuel.
- Spin on the new filter (1) until the sealing o-ring makes contacts with the sealing surface on the fuel filter head.

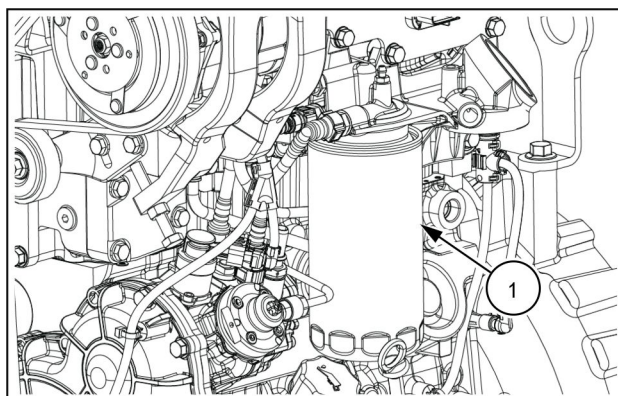

PTIL24TLB0329AB 2

## Diesel bleeding procedure

7. Ensure that diesel (minimum **20 L**) is available in the tank (minimum level varies with the size and capacity of the fuel tank, please contact equipment OM Manual for further informations). If leakages are there arrest it and ensure there is no blockage in the filter/pipe lines.
8. Loosen the bleed screw **(2)**.
9. Operate the hand pump and prime with fuel.
10. Actuate the pump until fuel comes without air from the bleed screw.
11. Tighten bleed screw **(2)**.

**NOTE:** Do not operate the starter motor for more than **10 s** continuously. Wait **30 – 60 s** before next attempt.

12. Before bleeding ensure that
  - Adequate diesel is available in fuel tank.
  - There are no damaged fuel pipes.
  - The copper washer at all the joints must be ok, otherwise priming takes more time due to entry of air and hence bleeding is not proper.
  - The pipe fittings are tight.
  - The suction strainer in fuel tank is clean.
  - Both the fuel filters and their seals are in good condition.
  - Fuel tank cap should be in good condition.
  - Fuel tank should have proper ventilation.
  - Fuel hoses should be in good condition and free of blockages.
  - \* Ensure all fuel lines routing as shown in image 4.

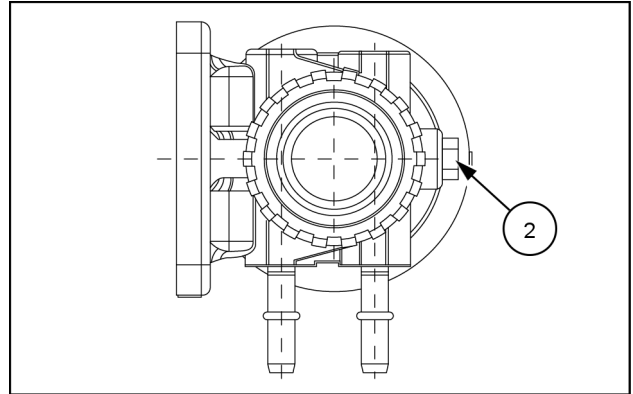

PTIL25COM0288AB 3

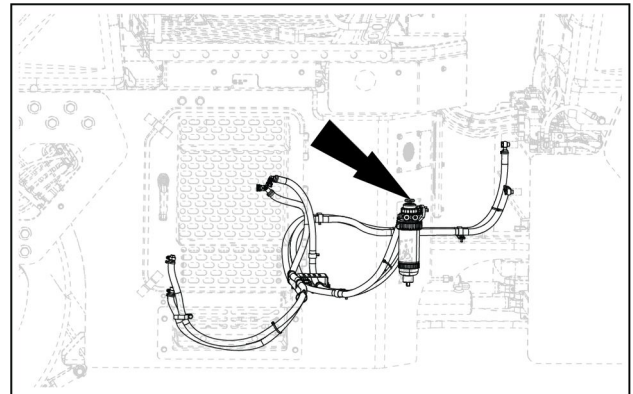

PTIL25COM0256JB 4

**NOTE:** Fuel additives should not be used.

**NOTE:** Keep fuel clean and prevent water from entering the fuel system.

**NOTE:** When filling the fuel tank in the rain or snow care should be taken not to allow water in the fuel tank. Do not forget to close the fuel tank cap securely.

## Radiator mounting bolts - Check and tighten

1. Check for the tightness of the radiator mounting bolts **(1)**.
2. If they are not tight, tighten the bolts **(1)** with the specified torque value of **25 ± 1 N·m**.

**NOTE:** While doing aforesaid activity, keep safe distance from fuel cooler sharp edge fins.

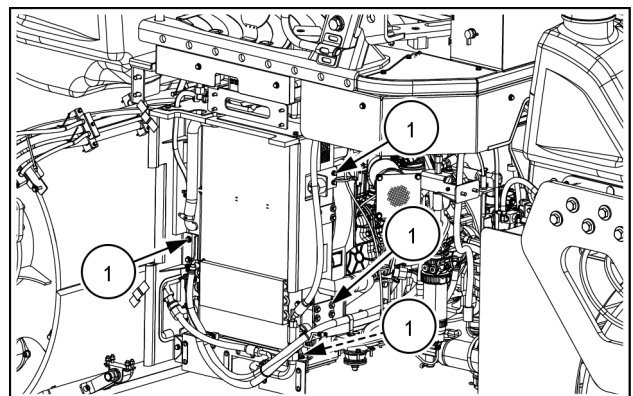

PTIL24COM1230AB 1

## Battery cells voltage and specific gravity - Check

For checking battery cells voltage, specific gravity and for the purpose of service and verification, see 7-22.

## Radiator, HOC and CAC fins - Cleaning

1. Open the left-hand side engine compartment door.
2. When mud, debris, etc. are stuck up at the front of the radiator or charge air cooler core, the passage of cooling air is impaired. Hence such matter should be removed completely by washing with water.
3. Deformed fins also can impair cooling, and these should be repaired. Check hoses for cracks, swelling or deterioration and replace if necessary.

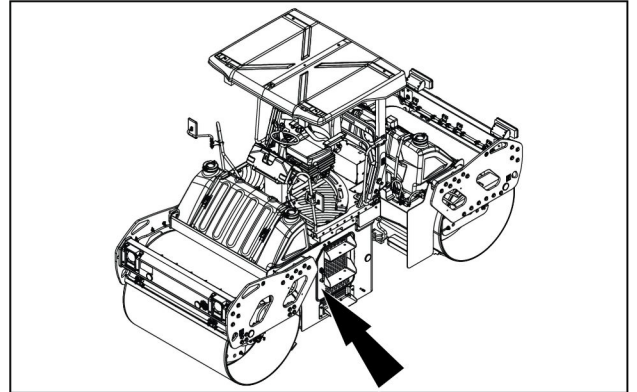

PTIL25COM0211AB 1

4. Clean the hydraulic oil cooler (1), radiator (2) and charge air cooler (3) using:
  - A. Use pressurized air to remove the dust.
  - B. Air to be applied from fan end.

**NOTE:** The cooling pack fin cleanliness condition should be regularly checked to clear with pressurized air to avoid any heating issues.

5. Make sure all dirt and debris have been removed especially in the area between the radiator, hydraulic oil cooler, and charge air cooler.

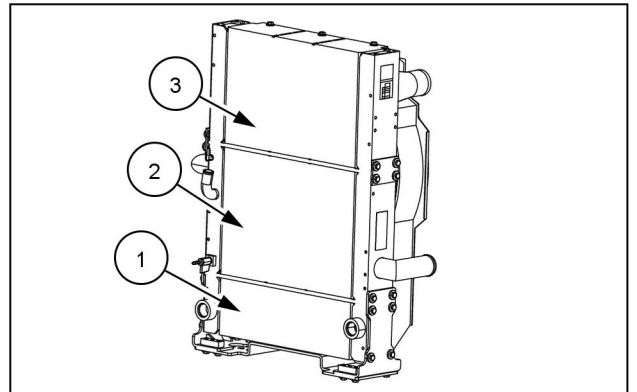

PTIL24COM1091AB 2

## Fuel strainer - Clean

**NOTICE:** Fuel tank and strainer cleaning procedure needs to be done only by an authorised personnel. Kindly contact your nearest CASE CONSTRUCTION dealer for further details. Failure to comply may lead to machine failure.

### Fuel tank strainer

1. Remove the fuel tank cap (1).
2. Remove the filler neck bolts and separate the filler neck (2) from the fuel tank (3).

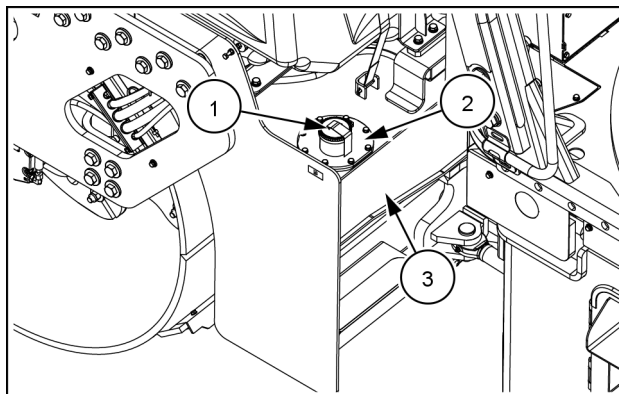

PTIL24COM1083AB 1

3. Remove the fuel suction strainer (4) and clean it.
4. After cleaning, install the fuel strainer (4) back to the fuel tank.

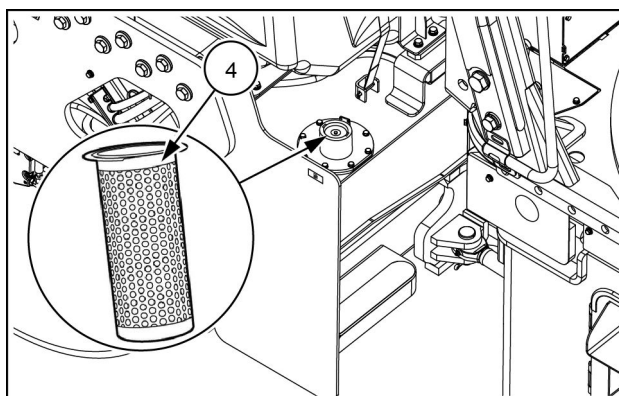

PTIL24COM1084AB 2

5. Install the filler neck (2) and tighten the bolts (5) to the torque value of  $25 \pm 15$  % N·m.
6. Install the filler neck cap (1).
7. Make sure that the fuel tank cap rubber seal is in good condition.

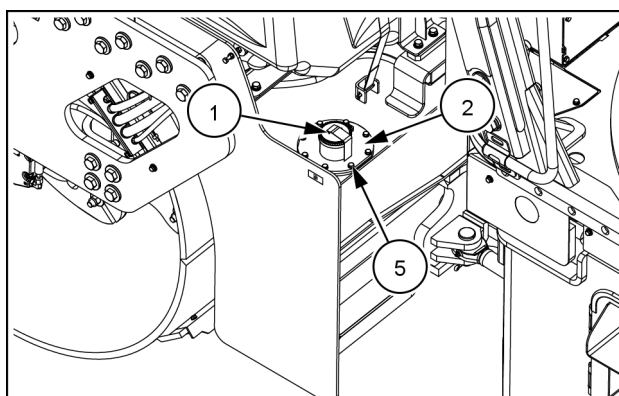

PTIL24COM1083AB 3

## Baby filter - Replace

1. Disconnect the hoses (1) from both sides of the baby filter (2).
2. Remove the baby filter (2).
3. Clean the fuel strainer mounting surface.
4. Install a new baby filter.

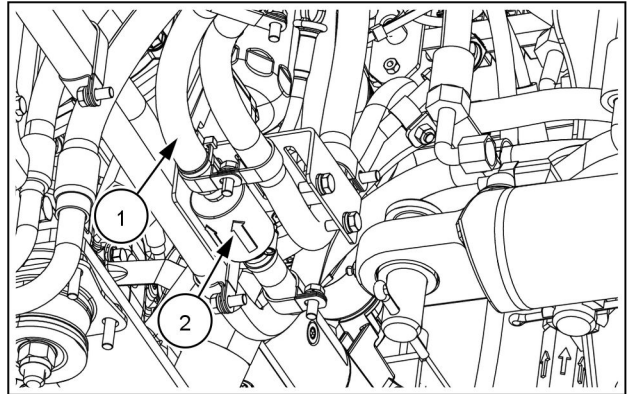

PTIL24COM1192AB 1

## Drain water from hydraulic tank

1. Drain out the sediments/water from the hydraulic tank by loosening the drain plug provided at the bottom of the tank by few threads.
2. Clean the area surrounding the drain plug of any remaining sediments.
3. Retighten the plug after the oil starts flowing out.



PTIL24COM1209AB 1

**Every 1000 hours or 12 months****Exhaust pipe mounting - Check and tighten**

**NOTICE:** Exhaust manifold check and tightening procedure needs to be done only by an authorised personnel. Kindly contact your nearest CASE CONSTRUCTION dealer for further details. Failure to comply may lead to machine failure.

1. Make sure that the exhaust manifold (DOC) clamp bolts (1) are installed tightly.
2. If it is loosely fitted, tighten the exhaust manifold (DOC) clamp bolts (1) to a torque value of **25±1 N·m**.
3. Make sure that the silencer pipe clamp bolts (2) are installed tightly.
4. If it is loosely fitted, tighten the silencer pipe clamp bolts (2) to a torque value of **25±1 N·m**.
5. If it is loosely fitted, tighten the catalyst clamp bolts (3) to a torque value of **25±1 N·m**.
6. After tightening the clamp bolts (1), (2) and (3), check for exhaust gas leakage.

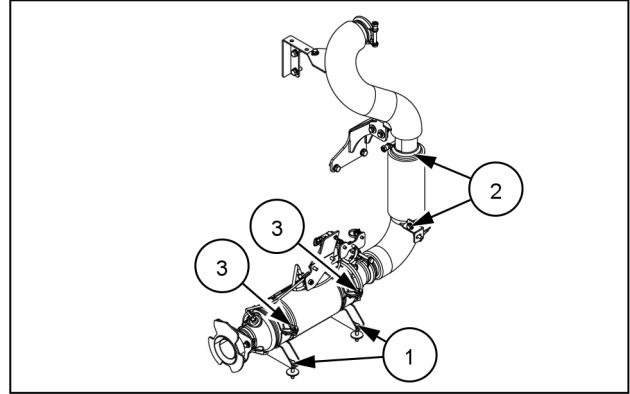

PTIL25COM0306AB 1

**Cuts and Damage in Wiring harness – Check**

**NOTICE:** Engine wiring harness routing procedure needs to be done only by an authorised personnel. Kindly contact your nearest CASE CONSTRUCTION dealer for further details. Failure to comply may lead to machine failure.

1. Check for any cuts and damages in wiring harness.
2. Make sure that the wiring harness is not rubbed against any sharp edges / hot zones / rotating or moving parts.
3. Make sure that the wiring harness is not to be routed and clamped with fuel lines.
4. Check for proper fitment of all earthing points.
5. Visually check the wiring harness for any fouling and correct the same.

**Drum oil - Replace**

1. Keep the machine on the level ground.
2. Turn the drum until oil plug is vertically positioned below the drum axis centre.
3. Clean surroundings of the plug.
4. Unscrew the oil drain plug (1). The oil will run out.

**NOTE:** Make sure that unscrew the correct oil drain plug.

5. Drain the oil completely and fill in with the fresh oil, for the capacity see 7-3.
6. Install the oil plug and tighten it.

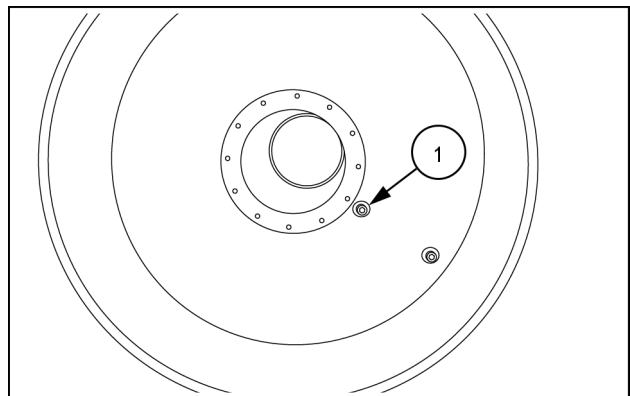

PTIL15COM2101AB 1

## Exhaust gas leakage check on all V band clamps

**NOTICE:** Exhaust gas leakage check procedure needs to be done only by an authorised personnel. Kindly contact your nearest CASE CONSTRUCTION dealer for further details. Failure to comply may lead to machine failure.

1. Make sure that the exhaust assembly pipes (1) are installed correctly.
2. Check the tightness of the V clamps (2) of the exhaust upper and lower tubes.
3. If there is any gas leakage, tighten the V clamps (2) to a torque value of **25±1 N·m**
4. After tightening the V clamps (2), check for gas leakage.

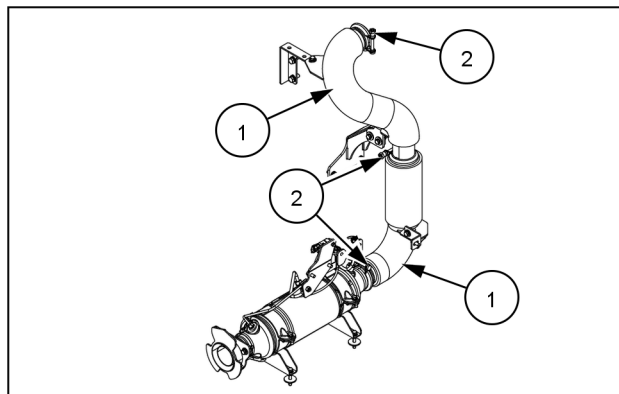

PTIL25COM0306AB 1

## Turbocharger mounting - Check

1. Check the tightness of the three bolts (1) along nuts and with the washers of the turbocharger mount.
2. Torque the bolts (1) and nuts if required.
3. The turbocharger mount is located on the engine of the vehicle connected to the air filter.
4. Periodically check the tightness of the bolts on the turbocharger mount.

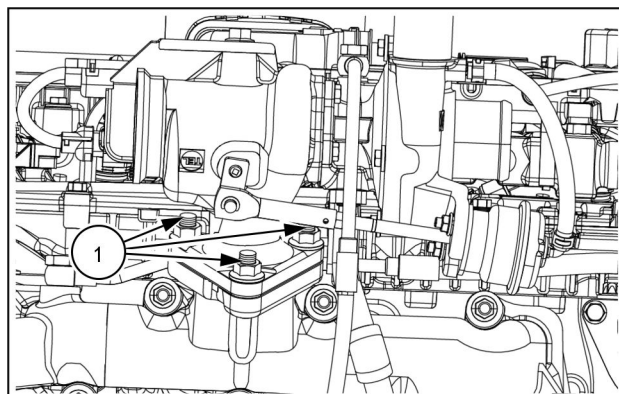

PTIL24COM1221AB 1

## Engine and cooling pack mounting rubber pad - Check and replace

**NOTICE:** Engine mounting rubber pads check and replace procedure needs to be done only by an authorised personnel. Kindly contact your nearest CASE CONSTRUCTION dealer for further details. Failure to comply may lead to machine failure.

1. Make sure that the engine assembly is mounted using the rubber pads.
2. Check all the engine mounting rubber pads (total 4) and cooling pack rubber pads (total 4) for any damage.

If there is any damage, do the following steps to remove the engine mounting rubber pads:

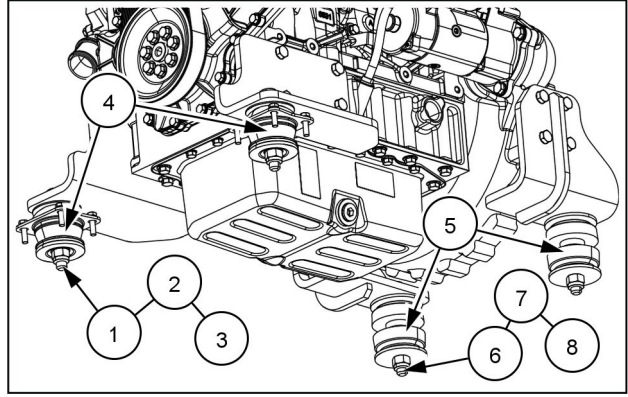

PTIL25COM0243AB 1

3. Make sure that the suitable lifting device is installed to the top of the engine.
4. Remove the two bolts (1) along with nuts (2) and washers (3) from the bottom of the engine rubber mounting pads (4).
5. Remove the two bolts (6) along with nut (7) and washers (8) from the bottom of the engine rubber mounting pads (5).
6. Remove the rubber mounting pads (4) and (5).
7. Engine need to be lifted to remove the AVMs and for installation as well.
8. Install the rubber pads (4) to the bottom of the engine and secure with the bolts (1) along with nuts (2) and washers (3).

**NOTE:** Tighten the bolts (1) to a torque value of 130 – 135 N·m.

9. Install the rubber pads (5) to the bottom of the engine and secure with the bolts (6) along with nuts (7) and washers (8).

**NOTE:** Tighten the bolts (6) to a torque value of 178 – 240 N·m.

If there is any damage, do the following steps to remove the cooling package mounting rubber pads:

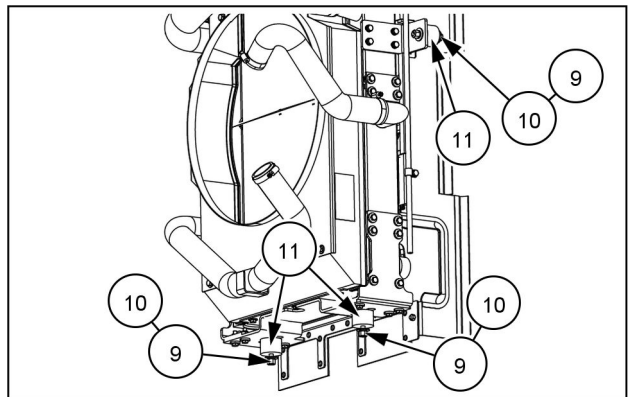

PTIL25COM0287AB 2

10. Remove the bolt (9) and washers (10) from the bottom and sides of the radiator rubber mounting pads (11).
11. Remove the rubber mounting pads (11).
12. Install the new radiator mounting rubber pads (11) and tighten with the bolt (9) and washers (10).

**NOTE:** Tighten the bolts (9) maximum to a torque value of 23 N·m.

## Travel Reduction gear box oil - Replace

1. For every 1000 h or 12 months replace the travel reduction gearbox oil, see 7-23.

Every 1500 hours or 18 months

## Fuel hoses - Check and replace

**NOTICE:** Fuel hoses replace procedure needs to be done only by an authorised personnel. Kindly contact your nearest CASE CONSTRUCTION dealer for further details. Failure to comply may lead to machine failure.

1. Make sure that the fuel hoses are installed correctly.
2. Check the fuel hoses for any damage.
3. If there is any damage, replace the old fuel hose with new one.
4. While replacing the fuel hose, ensure all clamp/cable tie are affixed and routing is done as shown in image 1.

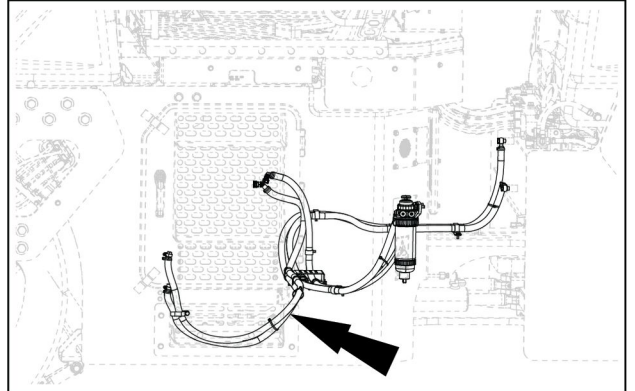

PTIL25COM0256JB 1

## Fan belt - Replace

For every 1500 h or 18 months replace the fan belt, see 7-15.

**Every 2000 hours**

**Drum bearing - Grease**

1. The drum bearing is located on the both the drums (diagonally) near vibration motor side. Open the grease nipple for draining at bottom side of bearing assembly.
2. Take grease hand pump and fill the grease nipple. Available at top side of bearing assembly.
3. Apply 95 strokes (approximately **450 g**) of grease from the hand pump (during the greasing, travel the machine in forward direction with single speed low RPM, no vibration mode, and drum to be rotated for one rotation).
4. Make sure old grease should come out from drain port at bottom side of bearing assembly, then plug the port with grease nipple.

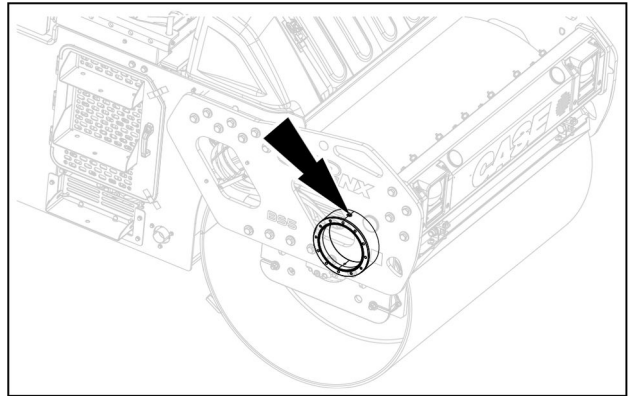

PTIL25COM0295AB 1

**Hydraulic oil - Replace**

1. Check the hydraulic oil level indicator (1) for level of the oil in the hydraulic tank (2).
2. Do the following steps to refill the oil:
  - Open the hydraulic oil filler cap (3).
  - Remove the plug (4) for draining of oil.
  - Drain the hydraulic oil from the drain port of the hydraulic tank (1).

**NOTE:** Dispose of the drained liquid as per local regulations.

- Make sure that the hydraulic tank (2) is free of dirt/ dust to avoid contamination.
- If there is any dirt / dust, clean the hydraulic tank (2).
- Install the plug (4).
- Refill the tank with new hydraulic oil through the hydraulic oil filler neck (5).

**NOTE:** For hydraulic oil specification, see **Consumables**.

- Make sure that the oil level is at the middle in the level indicator (1) in the hydraulic tank (2).
- Close the hydraulic oil filler cap (3).

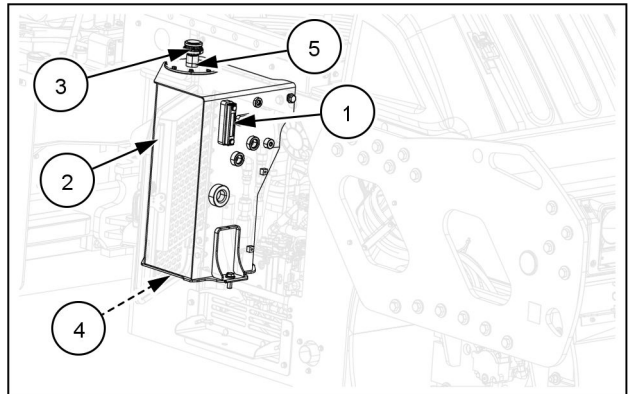

PTIL24COM1194AB 1

## Engine coolant - Replace

### ⚠ WARNING

**Hot liquid under pressure!**

Never remove the filler cap or the recovery tank cap while the engine is running or the coolant is hot. Let the system cool. Turn the filler cap to the first notch and allow any pressure to escape, and then remove the filler cap. Loosen the recovery tank cap slowly to allow any pressure to escape.

Failure to comply could result in death or serious injury.

W0296A

### ⚠ CAUTION

**Burn hazard!**

Hot coolant can spray out if you remove the filler cap while the system is hot. After the system has cooled, turn the filler cap to the first notch and wait for all pressure to release before proceeding.

Failure to comply could result in minor or moderate injury.

C0043A

**NOTICE:** Use of recommended coolant is very important to prevent corrosion of the cooling system and clogging of the radiator. Replace coolant as per the **Maintenance chart**. Drain and fill the cooling system with a new coolant.

1. Park the machine on a level surface and shut-off the engine.
2. Open the left hand side engine compartment door.
3. Place a container with sufficient capacity under the radiator drain cock (1).
4. Install a drain pipe on the drain cock (1) and put the other end into a container.
5. Open the radiator drain cock (1) and drain the coolant.
6. After the system is completely drained, close the drain cock (1).
7. Rinse the system with fresh water, drain again and then fill the system.
8. Check the condition of the hoses, connections and the water pump.
9. Make sure that the external surfaces of the engine and the radiator are clean.
10. Open the cover (2).

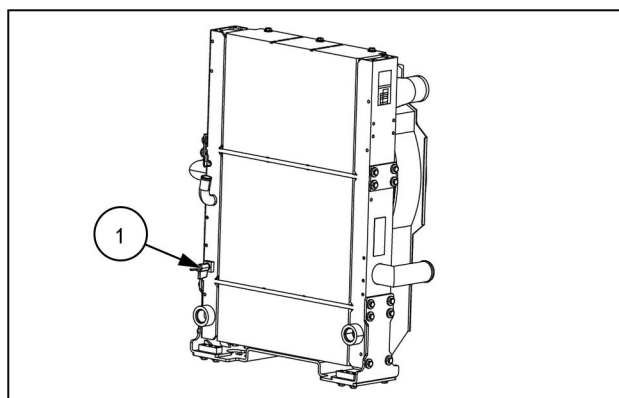

PTIL24COM1091AB 1

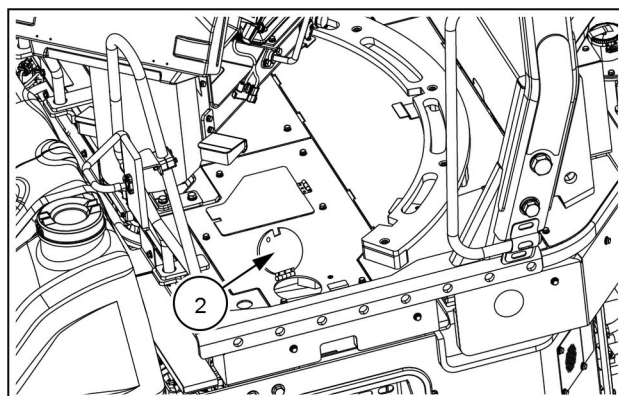

PTIL25COM0303AB 2

11. Remove the cap (3) and fill the coolant.
12. Fill the coolant reservoir (4) with coolant solution.

**NOTE:** Always use genuine and approved lubricants. Consult your CASE CONSTRUCTION dealer for any further information.

**NOTE:** Always fill the cooling system with coolant slowly to prevent the formation of air bubbles.

13. Retighten the cap (3) on the reservoir (4).
14. Run the engine for a few minutes and then check the level in the coolant reservoir (4) again.
15. Check for leakage and check the coolant level.
16. Top up if necessary.

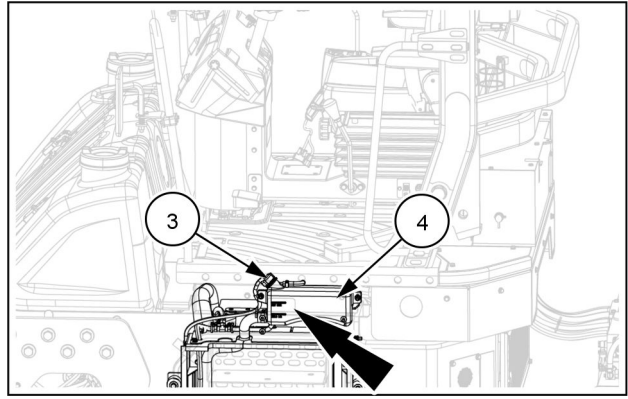

PTIL25COM0294AB 3

### Water pump

No frequent lubrication is required as the engines are fitted with "integral shaft and bearing" type water pumps with pre-packed grease.

### Radiator cowl arrangement

**NOTICE:** Improper radiator mounting can result in radiator hose failures as well as core cracks at dip soldered joints of top and bottom tanks.

Do not run the equipment without radiator cowl and safety guard.

Ensure that the radiator cowl mounting, and fan blade clearance are in proper order.

Check radiator mounting bracket bolts for tightness and the condition of the rubber pads and replace if found defective.

**NOTE:** The presence of the radiator cap prevents loss of coolant, entry of foreign particles and raises boiling point of coolant. The absence can lead to engine overheating and reduction in engine life.

### Suction Strainer - Clean

1. Open the right-hand side engine compartment door to access the suction strainer filter.
2. Loosen the hose clamp (1) and hose fitting (2) and disconnect the hydraulic suction hose (3).
3. Loosen and remove the suction strainer filter (4).
4. Clean the suction strainer filter (4) and re-install.
5. Tighten the suction strainer filter (4) to a torque value of 40 – 50 N·m.
6. Install and tighten the hose fitting (2) and hose clamp (1).

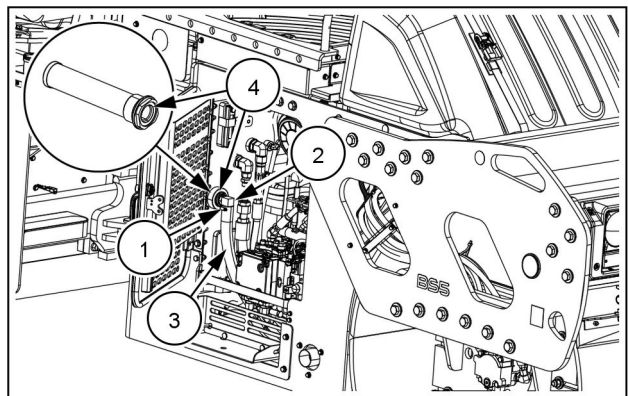

PTIL25COM0244AB 1

**NOTE:** Tighten the hose fitting (2) to a torque value of 40 – 50 N·m.

7. Connect the hydraulic suction hose (3).

**NOTE:** Tighten the hose clamp (1) to a torque value of 4.5 – 5.1 N·m.

Every 4000 hours

## Diesel Oxidation Catalyst (DOC) assembly - Replace

1. Loosen and remove the temperature sensors **(1)** and **(2)** from the DOC assembly.
2. Loosen and remove the DPF sensor outlet tube **(3)**.
3. Loosen the bolt **(4)** along with the nut **(5)** and remove the hose exhaust clamp **(6)**.
4. Loosen the bolt **(7)** along with the nut **(8)** and remove both the clamps **(9)**.
5. Remove the diesel oxidation catalyst **(10)** and replace with new one.

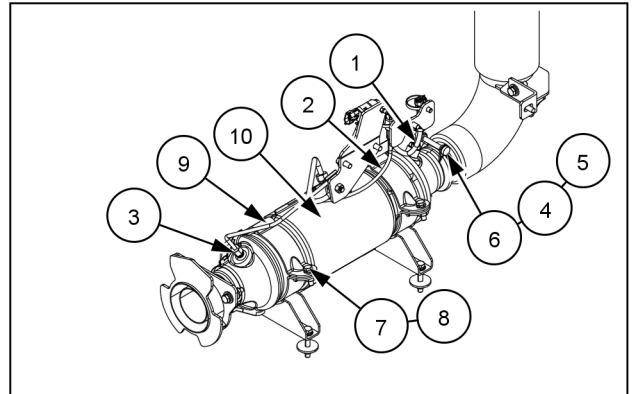

PTIL25COM0289AB 1

As required

## Water separator drain

For draining of fluid from water separator, see **7-9**.

## Engine air filter primary and secondary element - Replace

### Servicing instructions

- A. Replace primary and secondary element when indication is shown on cluster or after every **500 h**.

**NOTICE:** Do not tap or hit the element on hard surfaces as it can damage the element.

### Primary and secondary element

1. Open the right hand side engine compartment door.

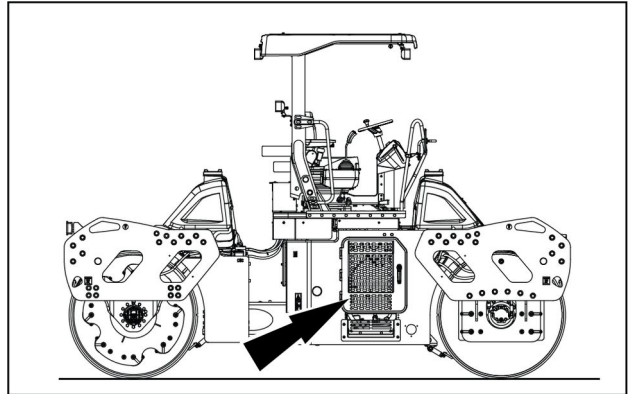

PTIL25COM0191AB 1

2. Pull the knob (1).
3. Remove the cover (2) by rotating in counter clockwise direction.

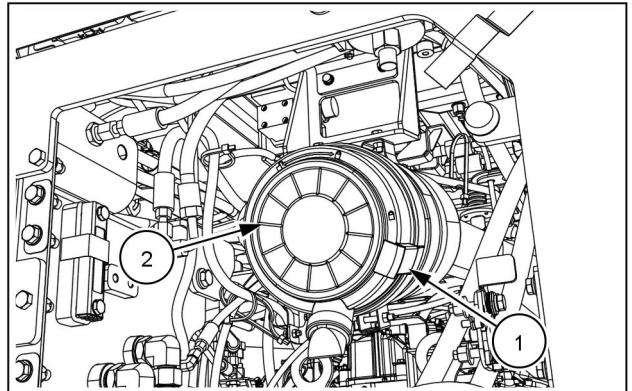

PTIL24COM1093AB 2

4. Remove primary and secondary air filter element (3) by rotating in counter clockwise direction.

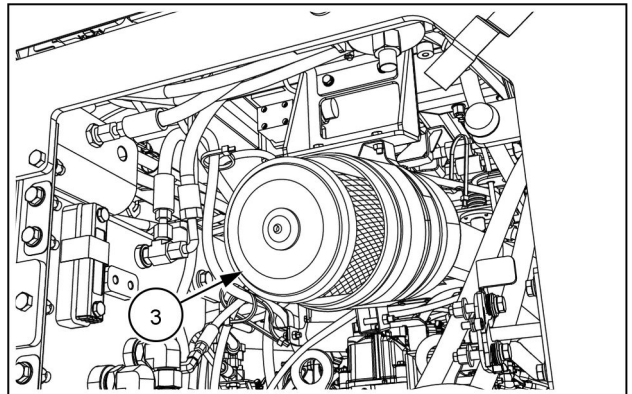

PTIL25COM0310AB 3

5. Clean the air filter housing and cover with clean cloth.
6. Hold the new primary and secondary air element horizontally and support the base with other end.
7. Fix the primary air element in housing by gently pressing the filter into the inlet port.

**NOTICE:** Please make sure that element is not touching the filter housing wall.

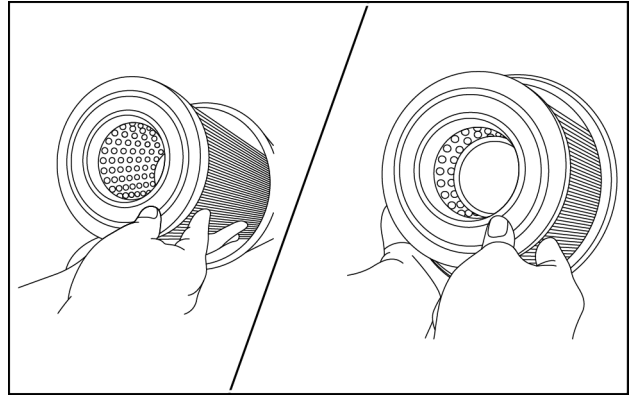

PTIL19TLB0008AA 4

8. Close the cover (2) by rotating clockwise and push the knob (1).

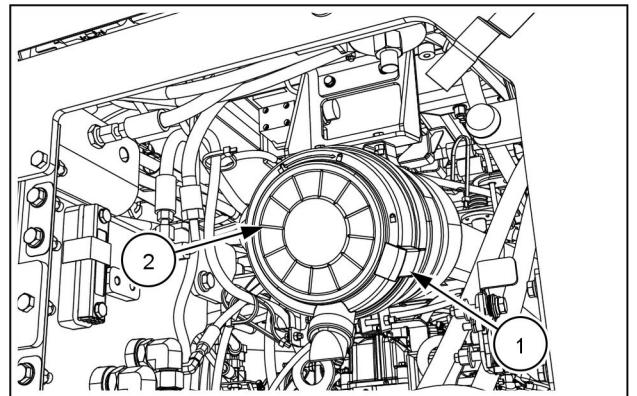

PTIL24COM1093AB 5

## Radiator, CAC - Cleaning whenever chocked

Clean the radiator and CAC whenever chocked, see 7-29.

While cleaning, take utmost care from sharp edges of CAC unit.

## Fan / alternator belt - Replace

1. Replace the fan/ alternator belt if required, see 7-35.

## Water sprinkling system - Cleaning

1. Cleaning the sprinkling tubes (1): Remove plugs of sprinkling tubes. (1). Flush tubes and refit plugs.
2. Cleaning of water filters (2): Remove the water filters (2). Thoroughly clean and refit the water filters (2).
3. Cleaning of nozzle (3): Remove the nozzles (3) by opening the nuts and clean the nozzle (3) with pin. Re-fit the nozzle (3) after cleaning.
4. Air Venting: Remove the plug at the front of water pump (4) and run the pump (4) to remove air from the system. After removal of air retighten the plug.

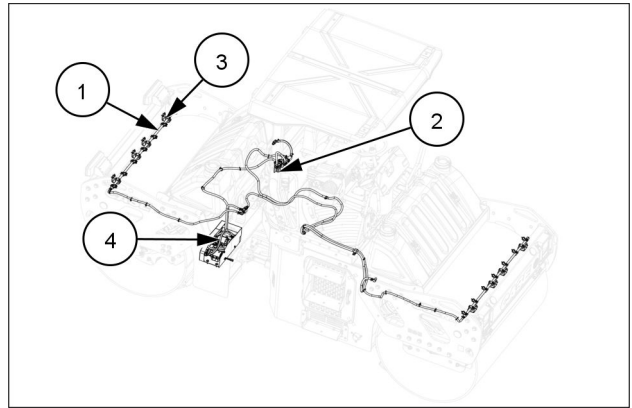

PTIL24COM1197FB 1

## Electrical systems - Check

1. Check all the electrical lines, fuses and connections (terminals, plug connectors etc).
2. Check lighting system, which consists of :
  - Head lamps
  - Front indicators
  - Rear indicators
  - Tail lamp
  - Working lights
3. Check the electric circuit of exciter and sprinkling system.
4. Check LED tails and instruments for functions.
5. Ensure Head lamps vertical/lateral alignment in the cut-out, and its rear mounting bolt is firmly tightened.

## Bleed air from the fuel system

When required bleed air from the fuel system, see 7-27.

## ATS V-clamps and gaskets - Replace

At the removal of exhaust manifold (ATS), follow the steps as given below:

1. Replace the V-clamps (1) with new ones.
2. After replacing, tighten the V-clamp bolts (2) and nuts (3) to the torque value of  $25 \pm 1 \text{ N}\cdot\text{m}$ .
3. Replace the gaskets with new one to avoid any gas leakage.

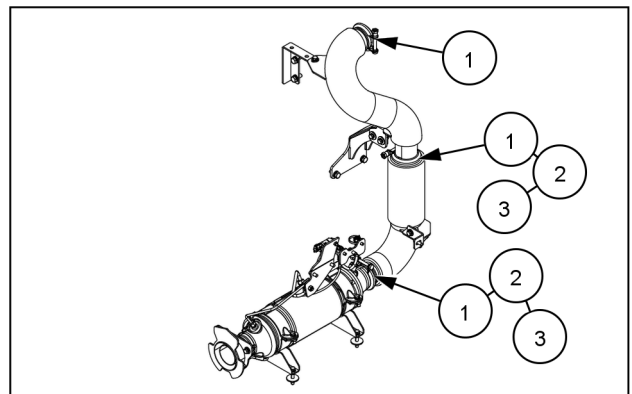

PTIL25COM0306AB 1

## **Fuel strainer - Clean**

When required clean the fuel strainer, see **7-30**.

## Storage

### Storing the machine

Geographic, environmental and actual storage conditions make it difficult to follow a set storage procedure for all areas and conditions. The following procedure is for a storage period of six months or longer. This procedure is a good starting point but may not be all inclusive. If you have questions about storing your machine, contact your CASE CONSTRUCTION dealer.

1. Prior to storing, inspect the machine for visible signs of wear, breakage or damage. Order any parts required and make the necessary repairs to avoid delays when starting the next operating period.
2. Prior to storing, wash the machine.
3. Lubricate the entire machine.
4. Paint any areas where the paint has been damaged.
5. Move all hydraulic controls through their complete ranges several times to relieve any pressure in the circuits.
6. Change the engine oil and replace the filter.
7. Drain the cooling system. Leave the drains open and do not tighten the radiator cap.
8. Put a DO NOT OPERATE tag.
9. Cover the exposed cylinder rods, and valve spools and any other bare metal parts with a rust and corrosion preventive.
10. Remove and clean the battery. Fully charge the battery. Store the battery in a cool dry place where it will not freeze.
11. Cover exhaust outlet.
12. Park the machine inside a building. If a building is not available, park the machine in a dry area on planks and cover with a waterproof cover.
13. Do periodic checks for protection. Look for corrosion.
14. Daily clean the sprinkler water marks on both chassis, the water hardness continuous deposition becomes hard, if not cleaned over prolong duration.

## Short term storage

1. If the machine is to remain unused for a period exceeding 30 days, store it under cover or cover it with a waterproof tarpaulin.
2. Clean the machine completely. Paint all surfaces of the machine where the paint work is damaged, to avoid rust.
3. Check the machine for worn or damaged parts and replace as necessary.
4. Lubricate the machine and drain the hydraulic oil tank, gearbox, and engine and refill with the correct grades of oil.
5. Check the radiator coolant level. If the machine is within **100 h** before the scheduled maintenance after **2000 h**, or within 2 months before the maintenance scheduled after 2 years, perform the prescribed maintenance operations.
6. Stop the engine and operate all the hydraulic controls to release all residual pressure from the hydraulic circuits.
7. Coat the exposed portions of the cylinder rods and control valve spools with grease.
8. Remove the battery from the machine and store it.
9. Cover the exhaust pipe opening.

## Storing the engine

If the engine is to be left unused for a long time, it is necessary to conserve it against rust formation.

1. Clean the engine with a high-pressure device.
2. Take the engine to the operating pressure, then stop it.
3. Drain the engine oil and fill it with fresh oil.
4. Fill fuel tank.
5. Let the engine run for approximately **10 min**.
6. Stop the engine.
7. Manually rotate the engine several times for cylinder and combustion chamber preservation.
8. Disassemble the belts and store them packed.
9. Spray some anti-corrosive grease in the pulley races.
10. Close the suction and the drain openings.

## Storage over a short period

11. The engine must be thoroughly washed.
12. The battery terminals should be disconnected.
13. The engine should be started and run for a few minutes at least once a week.

### Recommissioning of equipment after long storage

14. The cooling system should be flushed completely and refilled with recommended coolant.
15. The masking tapes used in preparation of storage should be removed.
16. The sump should be completely drained of the corrosion inhibiting oil and refilled with the recommended engine lubricating oil.
17. The filter elements should be replaced.
18. The complete electrical circuit, especially the charging circuit should be checked for correctness of connections.
19. Starter solenoid points and battery terminals should be cleaned. Starter motor and alternator brushes should be checked for proper contact with commutator.
20. Ensure that sensors / actuators and other components of the EDC system including wiring harness are in order.
21. Operate the engine on no load for **10 min** and check the engine thoroughly. Apply load and check engine parameters.
22. Diesel tank to be cleaned before recommissioning of Equipment as per cleanliness specification.
23. Old diesel to be removed from the tank and new diesel to be filled.
24. Diesel filters to be replaced.
25. All rubber parts including belts to be checked for cracks / abnormalities & to be replaced if necessary.

### Things to be followed when the engine is in storage

26. Check engine oil level daily.
27. Check engine coolant level daily.
28. Periodically check and ensure that radiator is intact and replace a defective thermostat or a missing header tank filler cap immediately as otherwise the efficiency of cooling system would be affected, and this will damage the engine.
29. To obtain a trouble free and enhanced engine life maintain the air cleaner as per recommended maintenance procedure.
30. After starting the engine, check for proper functioning of all instrument gauges and lights.
31. For coolant topping up, use only recommended coolant. For engine coolant specifications, see **Consumables**.
32. Fill up diesel tank at the end of each working day to reduce water condensation in the tanks.
33. Drain water, air and oil sediments from tanks (diesel and hydraulic tanks) once in a week.

34. Disconnect alternator / battery electrical connection while carrying out welding work on the equipment.
35. Maintain electrolyte level in the battery using distilled water.
36. Upon Key ON, the MIL would go on for some time and would subsequently go OFF on engine start. This is the normal functioning. In case the MIL continues to be ON after engine start, approach the nearest CASE CONSTRUCTION dealer for assistance.

### **Things not to be followed when the engine is in storage**

37. Don't carry out welding of equipment / equipment with EDC and battery connected, which will lead to damage the major electric/ electronic components and the damages / failures will not be covered under warranty.
38. Don't open the radiator pressure cap while the engine is still hot. If you do so, hot water can come out resulting in personal injury.
39. Don't loosen the coolant drain plug while the engine is still hot. If you do so, hot water can come out resulting in personal injury.
40. Don't operate starter for more than **10 s** at a time and wait for **30 – 60 s** before trying again.
41. Don't add cold water to a hot engine as this can lead to crack in crankcase and other associated parts.
42. Don't dilute Coolant with plain or de mineralized water for top up.
43. Fuel pump setting should not be tampered with.
44. Don't run the equipment with leakages of air, fuel, oil and coolant.
45. Don't accelerate engine after starting as well as before stopping, keep the engine at idling RPM for minimum **3 – 5 min**. This can prevent damage to turbo charger.
46. Don't switch off ignition key switch when the engine is in running condition, this will cause white smoke.
47. Don't remove the battery while engine is in running condition.

### **Battery storage**

Remove the batteries from the machine. Store them on a wooden table in a dry, cool, well ventilated room, if possible at a temperature above **0 °C (32 °F)** [optimum temperature **20 °C (68 °F)**].

Perform the following operations:

- The battery should be removed and prepared for storage in a dry place. The battery should be topped-up with distilled water and charged at regular intervals.
- Clean the battery.
- The acid from the battery should be drained dry and stored, however ensuring that the acid is refilled to the correct level and density and recharged at the time of recommissioning the battery.
- Check the acid concentration and the electrolyte level every two weeks.
- Fully recharge the battery when the acid concentration drops to **1.23 kg (2.71 lb)**.
- Keep the outside of the batteries clean and dry.

## Taking the machine back to service

### **⚠ WARNING**

**Unexpected machine movement!**

**Before starting the engine, be sure all controls are in neutral or disengaged. This prevents the accidental start up of power-driven equipment.**

**Failure to comply could result in death or serious injury.**

W0169A

### **⚠ WARNING**

**Inhalation hazard! Risk to operators and bystanders.**

**Avoid running the engine in confined areas. Make sure there is adequate ventilation at all times.**

**Failure to comply could result in death or serious injury.**

W0166A

To take the machine back to service after a long storage period, it is necessary to take some precautions:

1. Eliminate all engine protections. Fill in engine oil.
2. Reassemble and connect the batteries. Check the charge condition and the electrolyte level of the battery.
3. Check the level of the coolant solution.
4. Remove the cover from the exhaust pipe opening.
5. Remove the anti-corrosive grease from the cylinder rods and the other coated areas.
6. Check the operation of the electrical system.
7. Bleed air from the hydraulic system.
8. Check the operation of the steering system and braking system.
9. The engine should be cranked till the engine oil pressure builds up to around **2 Kg/cm<sup>2</sup>**. Then Start engine and ensure that the specified oil pressure is attained.
10. Change the fuel filters and fill the fuel tank if needed.
11. Tighten the cooling system drain valves.
12. Check the condition of the engine fan belt. Replace it if required.
13. Check the hydraulic fluid level.

14. Lubricate the machine grease fittings.
15. Use a petroleum based solvent and remove the rust and corrosion preventive from the hydraulic cylinder rods and control valves.
16. Install a fully charged battery.

**NOTE:** Check the battery periodically for the correct electrolyte level. Wear face protection and test the electrolyte with a hydrometer. When the hydrometer reading is near 1.215, charge the battery.

17. Check the wiring harness, incase observe any cut marks, repair the same before powering up the unit.
18. Remove air from the engine fuel lines.

**NOTE:** Before starting the engine, make sure there are no leaks, missing or broken parts.

19. Start the engine and run at idle speed for **2 min.** Check for leaks around the filters and drain plugs.
20. Operate all the hydraulic controls to make sure normal flow of hydraulic oil to all components.
21. Stop the engine and check the fluid levels of the engine cooling system and gearbox.

### **Remove the engine protections**

22. Remove the anti-corrosive grease from the pulley races.
23. Assemble the belts and adjust the tension after brief operation.
24. Reopen the suction and drain lines.
25. Operate the engine.

**NOTE:** Check the machine for leaks and for broken, defective or missing parts.



## 8 - TROUBLESHOOTING

### Fault code resolution

### Engine - Troubleshooting

Problem	Possible Cause	Correction
<b>The engine does not start</b>	Partially discharged batteries	Check, charge the batteries and, if necessary, replace them
	Corroded or loose connections to the battery terminals	Clean, inspect, tighten the nuts and, if necessary, replace the excessively corroded terminals and nuts
	Dirt or water accumulations in fuel lines	Disconnect the lines and the injection pump and carefully clean them, if necessary, clean and dry the fuel tank
	No fuel in the tank	Fill the tank
	No supply to the injection pump	Check and, if necessary, replace the supply pump
	Air in the fuel system	Check the lines, the fittings, the supply pump, the filters and the injection pump for the presence of air, then bleed the system
	Damaged starter motor	Repair or replace the starter motor
<b>The engine stops</b>	Irregular delivery of the supply pump	Check delivery on the workbench
	Dirt or water accumulation in fuel lines	Disconnect the lines and the injection pump and carefully clean them; if necessary, clean and dry the fuel tank
	Restricted fuel filters	Replace the filter cartridges
	Burnt or cracked valves	Replace the valves
	Air in the fuel system	Check the lines, the fittings, the supply pump, the filters and the injection pump for the presence of air, then bleed the system
	Damaged injection pump controls	Replace the damaged parts
<b>The engine overheats</b>	The centrifugal pump of the cooling system is faulty	Overhaul the pump and, if necessary, replace it
	Faulty temperature switch	Replace the temperature switch
	Radiator partially faulty	Eliminate possible scales by washing, check and repair possible tube leaks
	Scales in coolant passage compartments in cylinder heads and crankcase	Carefully wash
	Centrifugal pump drive belt and fan drive belt too slack	Check and adjust belt tension
	Insufficient coolant	Restore the level in the expansion tank by adding the prescribed fluid
	Incorrect timing of the engine	Check and correctly time the engine
	Restricted air filter	Clean the assembly and, if necessary, replace the filter element
<b>The engine has anomalous knocks</b>	Partially obstructed or damaged injectors	Clean, overhaul and correctly calibrate the injectors
	Dirt accumulations in fuel lines	Clean the lines and replace the visibly dented pipes. If necessary, clean the injection pump
	Drive shaft knocks caused by an excessive clearance of one or more crankshaft bearings or big end bearings or excessive shoulder clearance	Rectify the drive shaft pins, assemble bigger shoulder bearings and rings
	Unbalanced drive shaft	Check the alignment and the balance of the drive shaft and, if necessary, replace it
	Loose flywheel retaining screws	Replace the loose screws and torque all the screws to the recommended value

8 - TROUBLESHOOTING

<b>Problem</b>	<b>Possible Cause</b>	<b>Correction</b>
	Connecting rod axes not parallel	Straighten the connecting rods, check that the axes are parallel and, if necessary, replace the connecting rods
	Cylinder knocks due to anomalous wear	Bore the cylinder barrels and assemble bigger cylinders
	Noisy cylinder pin due to excessive clearance in hub and connecting rod bushing. Bushings free in their seat on the connecting rod	Replace the pin with a bigger one, reprocess the hubs on the cylinder and the bushing on the connecting rod. Replace the bushing
	Ticking due to noisy distribution	Check that there are no broken springs, that there is no excessive clearance between the rods and the rails, tappets and seats. Adjust the clearance between valves and rockers
<b>Anomalous engine smoke</b>		Contact your CASE CONSTRUCTION Dealer
<b>Difficult starting and poor performance under all conditions</b>	High-pressure pump faulty	Contact your CASE CONSTRUCTION Dealer
<b>Difficult start, poor performance, the engine runs with one cylinder less</b>	Injector with shutter or solenoid core (mechanical part) stuck open.	Contact your CASE CONSTRUCTION Dealer
<b>Starting takes tens of seconds, too much white exhaust smoke, smell of fuel</b>	Injector (irreversibly) stuck open	Contact your CASE CONSTRUCTION Dealer
<b>Broken high-pressure line from pump to common rail</b>	Anomalous vibrations caused by a loose line clamping	Contact your CASE CONSTRUCTION Dealer
<b>The engine operates with a cylinder less, without saving failures in the control unit</b>	Injector stuck closed	Contact your CASE CONSTRUCTION Dealer

## Starter motor - Troubleshooting

Problem	Possible Cause	Correction
<b>The starter motor does not run</b>	Too low specific gravity and battery level	Inspect the battery
	Poor ignition switch circuit connection or contact	Replace the wiring harness and the ignition switch or starter motor runs too slowly
	Malfunction of the coil or of the magnetic switch pull-in cylinder	Replace the magnetic switch
<b>The starter motor running cannot crank the engine</b>	The pinion gear does not engage with the ring gear	Repair or replace the clutch and the control lever
	Sliding clutch	Replace the clutch
<b>Anomalous noise</b>	Anomalous bushing wear	Replace starter
	Wear on pinion gear or ring gear tooth tips	For ring gear damage contact CASE CONSTRUCTION Dealer
	Poor pinion gear sliding	Replace starter
<b>The pinion gear springs</b>	Poor ignition switch return	Replace the ignition switch
<b>Field coil loss. Magnetic switch coil burnt, etc.</b>	Pinion gear disengagement fault caused by a coil short circuit in the magnetic switch	Replace the magnetic switch

## Alternator - Troubleshooting

Problem	Possible Cause	Correction
<b>Not recharged</b>	Recharge circuit interrupted (warning lamp, fuse, connector, etc.)	Check the connections of the recharge circuit, clean and tighten the alternator and battery terminals
	Voltage regulator inefficient	Replace alternator
	Rotor winder interrupted	Replace alternator
	Worn brushes	Replace alternator
<b>Recharge insufficient</b>	Slackened fan belt	Supply the correct tension
	Voltage regulator faulty	Replace alternator
	Excessive wear of rotor rings or brushes	Replace alternator
	Short-circuited diodes	Replace alternator
	Short-circuited stator winders or rotor winder	Replace alternator
<b>Excessive recharge</b>	Loose circuit connections	Check the connections of battery terminals, starter motor terminals and alternator
	Voltage regulator inefficient	Replace alternator
	Ground connection faulty	Check connections for leaks

## Hydraulic systems - Troubleshooting

Problem	Possible Cause	Correction
<b>Machine not moving in forward / reverse direction</b>	Parking brake switch applied and/or towing valve in towing position	Set parking brake switch and/or towing valve to driving position. See Sec. "4-operating instructions"
	Lack of oil in hydraulic oil tank	Check oil level in the hydraulic oil tank and refill fresh oil, if necessary. See Section "6-Working operation"
	Error in the adjusting device for the control lever on the variable displacement hydraulic pump	Check adjusting device for correct function and readjust, if necessary
	Propulsion interrupted	Check coupling between engine and variable displacement hydraulic pump as well as connection between the variable displacement hydraulic motor and the drums and have them overhauled, if necessary, by the service engineer
	No or insufficient charge pressure	Check charge relief valve setting on Travel & vibration pump OR contact CASE CONSTRUCTION dealer.
	Hydraulic oil filter clogged Suction line clogged	Check suction line and replace hydraulic oil filter element
	Driver of charge pump sheared off Charge circuit pressure relief valve not closing in	Contact CASE CONSTRUCTION Dealer
	Low and fluctuating charge pressure. Air causes noise within hydrostatic drive	Tighten all connections between the hydraulic oil tank and the charge pump through which air may penetrate
	Internal components in variable displacement hydraulic pump or hydraulic motors damaged	Contact CASE CONSTRUCTION Dealer
	Charge circuit non-return valves defective	Contact CASE CONSTRUCTION Dealer
	Internal components in variable displacement hydraulic pump or hydraulic motor damaged as seen by: Brass particles, chips, or flakes in hydraulic oil tank and filter	Contact CASE CONSTRUCTION Dealer
	Very noisy operation of variable displacement hydraulic pump or hydraulic motors	Tighten all connections between the hydraulic oil tank and the charge pump through which air may penetrate
	No, low or fluctuating charge pressure	Replace hydraulic oil filter or tighten all connections between the hydraulic oil tank and the charge pump through which air may penetrate
	Hydraulic oil filter clogged	Replace hydraulic oil filter
Parking brake not releasing	Replace hydraulic oil filter or tighten all connections between the hydraulic oil tank and the charge pump through which air may penetrate	
<b>Propulsion operating in one direction only</b>	Error or defect in adjusting device for the control lever of the variable displacement pump	Check and adjust device for correct function and readjust if necessary
	Main pressure relief valves not closing	Tighten main pressure relief valves. If propulsion does not yet operate in the other direction, exchange both main pressure relief valves against each other. If propulsion now operates in other direction, one of the main pressure relief valves does not close. Contact CASE CONSTRUCTION Dealer
	Charge circuit non-return valves defective	Contact CASE CONSTRUCTION Dealer

8 - TROUBLESHOOTING

<b>Problem</b>	<b>Possible Cause</b>	<b>Correction</b>
<b>Zero setting can not be obtained any more</b>	Error in adjusting device for control lever of variable displacement hydraulic pump	Check adjusting device for correct function and readjust, if necessary
<b>Travel circuit overheating (Exceeding 90°)</b>	Hydraulic oil cooler clogged	Clean cooling devices
	Lack of oil in hydraulic tank	Fill in fresh oil, if necessary
	Hydraulic oil filter and/or suction line clogged	Replace hydraulic oil filter
	Internal leaks, Pump relief valves jamming and not full closing. Internal components in variable displacement hydraulic pump or hydraulic motors damaged	Contact CASE CONSTRUCTION Dealer
<b>Noise during travel operation.</b>	Air in propulsion. Lack of oil in Hydraulic oil tank. Suction lines leaking	Check oil level in hydraulic oil tanks and fill fresh oil if necessary. Check suction lines for leaks. Note:- Heavy foaming in hydraulic oil tank is an indication of air in the propulsion
	Insufficient hoses and pipe clearance or insulation	Hoses and pipes must not come into contact with metal. Coat hose clips and pipe clamps with rubber for the purpose of noise insulation
	Internal Components in variable displacement hydraulic pump or hydraulic pump or hydraulic motors damaged	Get the system repaired by the "Service Engineer"
<b>Sluggish acceleration and deceleration</b>	Decreased engine power	See Engine operator's manual
	Air in propulsion Lack of oil in hydraulic tank Suction lines leaking	Check oil level in hydraulic tank and refill fresh oil, if necessary Check suction lines for leaks. Note: Heavy foam generation in hydraulic oil tank is an indication of air in the propulsion.
	Internal components in variable displacement hydraulic pump or hydraulic pump or hydraulic motors damaged	Get the system repaired by the "Service Engineer"
	Insufficient charge pressure. Hydraulic oil filter clogged. Suction line clogged. Charge circuit pressure relief valve in filling pump not closing internal components in variable displacement hydraulic pump or hydraulic motors damaged	Check charge pressure. Replace hydraulic oil filter. Clean suction line. Contact CASE CONSTRUCTION Dealer
	Internal wear or damage to variable displacement hydraulic pump or motor	Get the system repaired by the "Service Engineer"
<b>Exciter drive not functioning (drum not vibrating)</b>	Lack of oil in hydraulic tank	Check oil level in hydraulic tank and refill fresh oil, if necessary. Eliminate leaks
	Error in the adjusting device	Check adjusting device for proper function and reset, if necessary
	Exciter drive interrupted	Check coupling between engine and pump as well as connection between constant displacement hydraulic motor and exciter shafts and have them overhauled, if necessary by CASE CONSTRUCTION Dealer
	Low or no charge pressure	Check charge pressure
	Hydraulic oil filter clogged	Replace hydraulic oil filter
	Suction line clogged	Clean suction line
	Charge pump not working, internal component damage in variable displacement hydraulic pump or constant displacement hydraulic motor	Contact CASE CONSTRUCTION Dealer

8 - TROUBLESHOOTING

Problem	Possible Cause	Correction
	Low or fluctuating charge pressure. Air causes noise in hydrostatic	Tighten all components between hydraulic oil tank and the charge pump through which air may penetrate
	Internal damage in hydraulic pump or hydraulic motors are damaged	Get Repaired by the "Service Engineer"
	Charge circuit non-return valves. Not functioning	Contact CASE CONSTRUCTION Dealer
	Internal components in variable displacement hydraulic pump or constant displacement hydraulic motor defective	Contact CASE CONSTRUCTION Dealer
	Hydraulic filter clogged	Replace hydraulic oil filter
	Exciter system circuit defective	Check exciter system circuit
<b>Exciter drive operating in one direction only (only one frequency operating)</b>	Error or defect in the adjusting device for the control lever of the variable displacement hydro pump	Check the adjusting device for correct function and readjust, if necessary
	Operating over pressure relief valve not closing	Tighten main pressure relief valves. If propulsion does not yet operate in the other direction. Exchange both operating over pressure relief valves against each other. If propulsion now operates in the other direction, one of the other operating over pressure relief valves does not close. Get it checked by CASE CONSTRUCTION Dealer
<b>Neutral position can not be obtained anymore</b>	Error in adjusting device	Check adjustment device for proper operation and reset, if necessary
<b>Exciter drive overheating (Exceeding 80 °C (176 °F))</b>	Exciter drive overheating (Exceeding 80 °C (176 °F))	Instantly stop engine and do trouble shooting procedure same as propulsion heating
<b>Noise in exciter drive</b>	Air in exciter drive, lack of oil in hydraulic oil tank, suction lines leaking	Check oil lines in hydraulic oil tank and refill refresh oil if necessary. Check suction line for leaks, eliminate leaks. Note: Heavy foaming in the hydraulic tank is an indicating of air in the exciter drive
	Internal wear damage in variable displacement hydraulic pump or constant displacement hydraulic motor	Contact CASE CONSTRUCTION Dealer

---

## Gearbox - Troubleshooting

<b>Problem</b>	<b>Possible Cause</b>	<b>Correction</b>
<b>Overheating</b>	Insufficient oil level	Check the oil level and refill if necessary
	Hydraulic oil too warm	Check the hydraulic circuit
	Brake not fully released	Check brake release pressure
<b>Insufficient power</b>	Internal motor parts damaged	Contact CASE CONSTRUCTION Dealer
<b>Insufficient braking torque</b>	Brake discs worn	Replace brake disc pack
	Damaged parts	Check brake components



# 9 - SPECIFICATIONS

## Machine dimensions

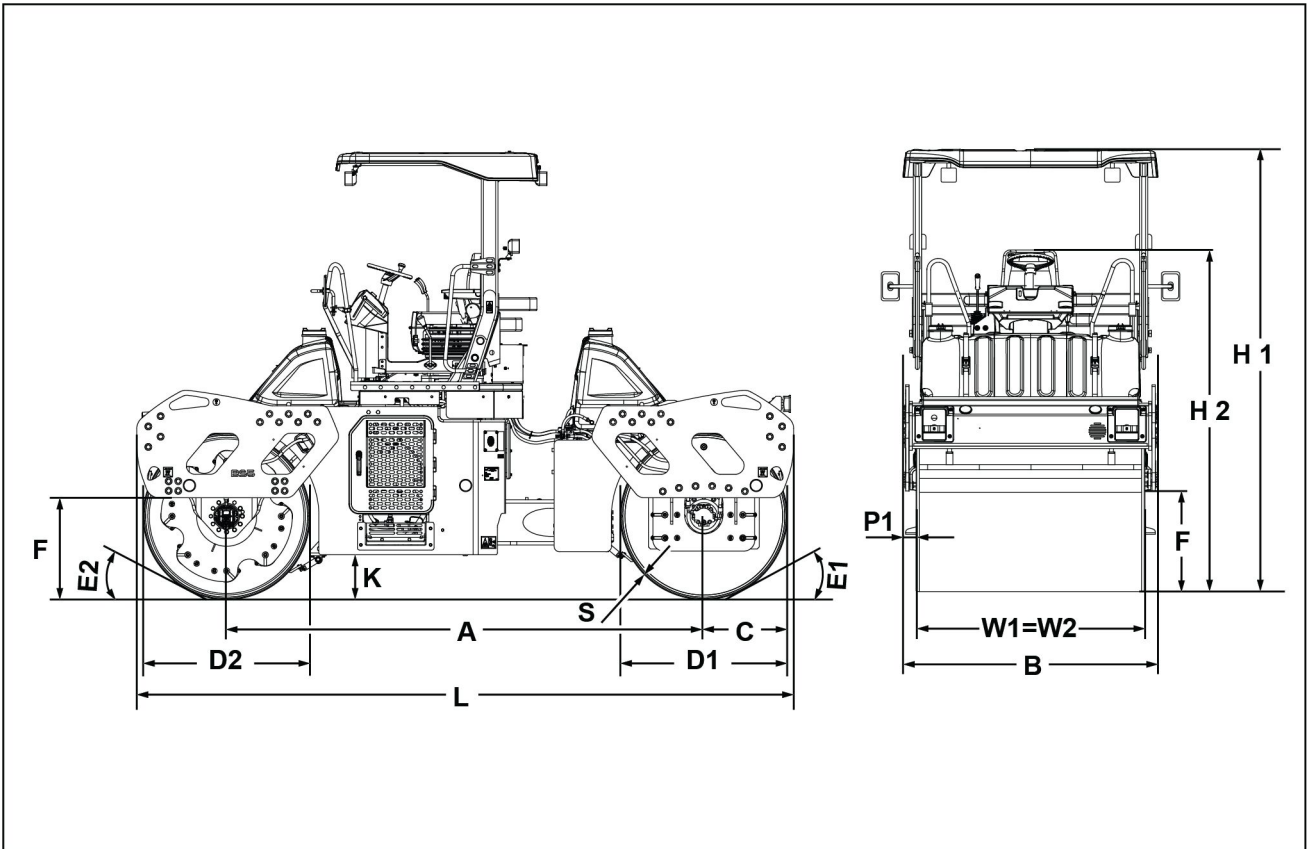

PTIL25COM0216FB 1

Denotations	Parameters	Dimension
A	Wheelbase	3490 mm
B	Overall width of the machine	1865 mm
C	Rear overhang	657 mm
D1	Diameter of rear drum	1220 mm
D2	Diameter of front drum	1220 mm
H1	Overall height of the machine	3280 mm
H2	Ground to steering wheel height	2460 mm
K	Ground clearance	322 mm
L	Overall length of the machine	4804 mm
P1	Side overhang	94 mm
S	Drum shell thickness	17 mm
W1=W2	Overall width of the drum	1675 mm
E1 and E2	Front and rear departure Angle	85°
F	Curb Clearance	745 mm

**NOTE:** Dimensions mentioned may vary within  $\pm 2.5\%$ .

## Operating weights

Parameters	Values
Total Operating Weight (Operator weight 75Kg) as per IS:5500-1	<b>8824 kg</b>
Shipping weight - as per IS:5500-1	<b>8298 kg</b>
Total Weight as per ARAI	<b>9200 kg</b>
Front Axle load	<b>4600 kg</b>
Rear Axle load	<b>4600 kg</b>
Static Linear Load Front	<b>27.5 kg/cm</b>
Static Linear Load Rear	<b>27.5 kg/cm</b>

## Vibration system

Parameters	Vibration Stage 1 (Low frequency)	Vibration Stage 2 (High frequency)
Frequency**	<b>36.5 Hz</b>	<b>50 Hz</b>
Amplitude	<b>0.9 mm</b>	<b>0.4 mm</b>
Centrifugal force	<b>7700 kgf</b>	<b>6050 kgf</b>
Max. Applied Force	<b>12400 kgf</b>	<b>10700 kgf</b>

\*\* Vibration frequency is set on the machine after lifting it off the ground. Hence actual frequency will vary when measured on ground.

## Engine specifications

Parameters	Specification
Fuel injection	Bosch Common Rail System (CP4.1)
Air intake	Turbocharger with intercooler
Air cleaner	Dry type with Replaceable element & coupled with Pre-cleaner
Engine oil filter	Spin on type
Cooling	Liquid Cooled
After treatment system	DOC +DPF
Emission compliance	CEV stage-V
Charging system	Turbo charged and after cooled
Gross rated power ( ISO14396)	<b>55.0 kW (74.8 hp) @ 2200 RPM</b>
Engine speeds:	
Rated speed (full load)	<b>2150 – 2250 RPM</b>
Low Idle speed (No load) – On vehicle	<b>925 – 975 RPM</b>
High Idle speed (No load) – On vehicle	<b>2375 – 2425 RPM</b>
High Idle speed (No load) – Vehicle operating	<b>2075 – 2125 RPM</b>

## Propulsion

Parameters	Specification
Propulsion type	Hydrostatic system acting on both the drums
Engine to Pump drive ratio	Direct Drive 1:1
Travel pump	Variable Displacement, Bi- directional axial piston pump with manual displacement control
Travel motor	High speed - low torque bi-directional motor
Gearbox	Reduction gear box. Brake on both drums
Actuation type	Through push pull cable assembled on a FNR lever assembly

## Exciter drive

Parameters	Specification
Type	Hydrostatic system acting on the front and rear exciter shafts
Kind of exciter	Single shaft with two floating masses for dual amplitude
Vibration Motor	Fixed displacement axial piston motor
Vibration pump	Variable displacement , axial piston pump with electrical displacement control

## Steering system

Parameters	Specification
Type	Hydrostatic system acting via the steering wheel, steering unit and steering cylinder mounted in the articulated joint
Steering lock angle or articulation angle (left-hand side and right-hand side)	$\pm 29^\circ$
Oscillation angle	$\pm 10^\circ$
Steering wheel outside diameter	342 mm
Steering wheel turns from lock to lock	7
Steering effort	1.5 kg
Standard version	Fixed type steering
Inner turning radius (A)	6 m
Outer turning radius (B)	7.75 m
Inner machine clearance radius (C)	5.9 m
Outer machine clearance radius (D)	7.9 m

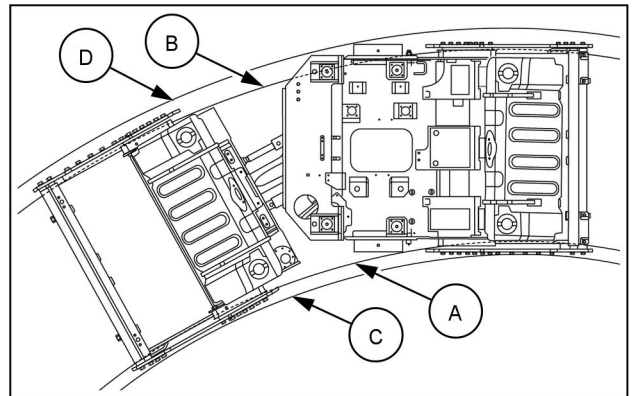

PTIL25COM0305AB 1

## Electrical system

Parameters	Specification
Type of ground	Negative (chassis ground)
System voltage	<b>12 V</b>
Battery quantity	1
Battery capacity	<b>110 A·h</b>
Alternator	<b>12 V, 120 A</b>
Starter motor	<b>12 V, 3.2 kW</b>

## Hydraulic oil filter

Parameters	Specification
Type	Cartridge type
Filter rating	<b>10 µm ( 10 microns)</b>
Number of filters	1

## Brakes

Parameters	Specification
Parking brake type	SAHR (Spring Applied Hydraulically Released)
Brake fully releasing pressure	<b>14 bar</b>
Brake maximum capable pressure	<b>50 bar</b>

## Sprinkling

Parameters	Specifications
Type	Pressurized water sprinkling system
Water tank	<b>390 L (Each)</b>
Pump material	Plastic housing - Polypropylene
Pressure	<b>4.8 bar</b>
Current	<b>7 A (Max)</b>

## Relief valve settings

Parameters	Specification
Travel circuit	<b>34500 kPa (345 bar)</b>
Vibration circuit	<b>34500 kPa (345 bar)</b>
Steering circuit	<b>16000 – 16500 kPa (160 – 165 bar)</b>

## Special torques

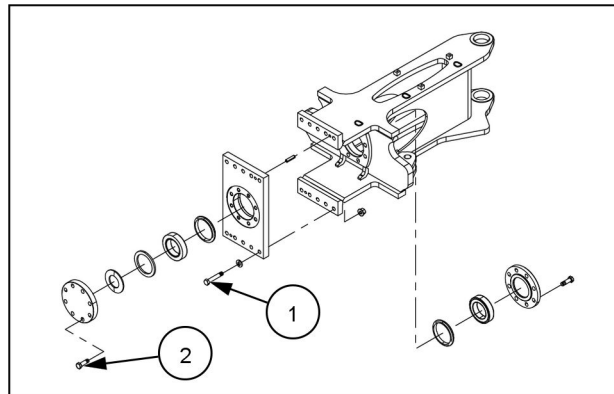

PTIL25COM0083AB 1

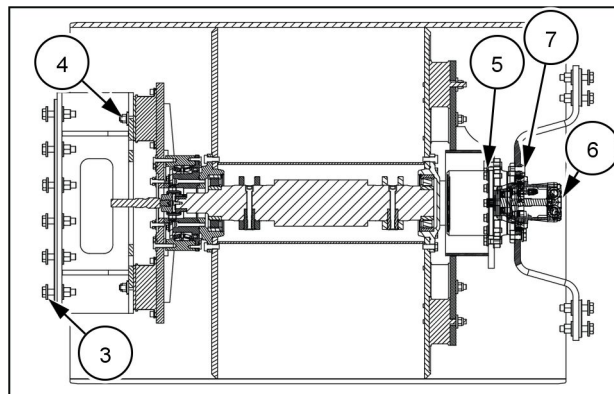

PTIL25COM0260AB 2

1	Articulation joint end plate mounting bolts	<b>27 +/- 15 kgm</b>
2	Articulation joint cover to articulation joint	<b>27 +/- 15 kgm</b>
3	Travel side plate to gearbox bracket	<b>690 +/- 10% N·m</b>
4	AVM mounting bracket to drum mount	<b>206 +/- 15% N·m</b>
5	Drive top plate to gearbox drive plate cover	<b>300 +/- 15% N·m</b>
6	Drum motor	<b>86 +/- 15% N·m</b>
7	Gearbox bracket	<b>300 +/- 15% N·m</b>

## Torque specifications

Size	Grade 8.8	Grade 10.9
M3	1.5 N·m (1.1 lb ft)	2.1 N·m (1.5 lb ft)
M4	3.5 N·m (2.6 lb ft)	5 N·m (4 lb ft)
M5	7.0 N·m (5.2 lb ft)	10 N·m (7 lb ft)
M6	11.8 N·m (8.7 lb ft)	17 N·m (13 lb ft)
M8	28.8 N·m (21.2 lb ft)	41.3 N·m (30.5 lb ft)
M10	57.3 N·m (42.3 lb ft)	81.8 N·m (60.3 lb ft)
M12	100 N·m (74 lb ft)	143 N·m (105 lb ft)
M14	159 N·m (117 lb ft)	227 N·m (167 lb ft)
M16	248 N·m (183 lb ft)	354 N·m (261 lb ft)
M18	352 N·m (260 lb ft)	487 N·m (359 lb ft)
M20	500 N·m (369 lb ft)	690 N·m (509 lb ft)
M22	681 N·m (502 lb ft)	942 N·m (695 lb ft)
M24	865 N·m (638 lb ft)	1195 N·m (881 lb ft)
M27	1262 N·m (931 lb ft)	1749 N·m (1290 lb ft)
M30	1719 N·m (1268 lb ft)	2377 N·m (1753 lb ft)
M36	2999 N·m (2212 lb ft)	4149 N·m (3060 lb ft)

## Unions, connections and plugs

Diameter * Pitch	
M10 x 1	20.0 N·m (14.8 lb ft)
M12 x 1.5	35 N·m (26 lb ft)
M14 x 1.5	45 N·m (33.2 lb ft)
M16 x 1.5	60 N·m (44 lb ft)
M18 x 1.5	70 N·m (52 lb ft)
M22 x 1.5	100 N·m (74 lb ft)
M27 x 2	200 N·m (148 lb ft)
M33 x 2	280 N·m (207 lb ft)
M42 x 2	380 N·m (280 lb ft)

## Nuts for pipes and hoses

Diameter * Pitch	
M16 x 1.5	20 N·m (14.8 lb ft)
M18 x 1.5	35 N·m (26 lb ft)
M20 x 1.5	45 N·m (33.2 lb ft)
M24 x 1.5	60 N·m (44 lb ft)

## Flanges

Diameter * Pitch	
M8 X 1.5	28 N·m (21 lb ft)
M10 x 1.5	55 N·m (41 lb ft)
M12 x 1.75	90 N·m (66 lb ft)
M14 x 2	145 N·m (107 lb ft)
M16 x 2	230 N·m (170 lb ft)

# Index

---

<b>A</b>	
Access to operator's platform . . . . .	3-1
Air restriction / vacuum indicator - Check . . . . .	7-14
Alternator - Troubleshooting . . . . .	8-3
ATS V-clamps and gaskets - Replace . . . . .	7-42
<b>B</b>	
Baby filter - Replace . . . . .	7-31
Battery cells voltage and specific gravity - Check . . . . .	7-29
Battery electrolyte level - Check . . . . .	7-21
Battery storage . . . . .	7-47
Battery terminals - Check and lubricate (if required) . . . . .	7-22
Before using the machine . . . . .	4-2
Bleed air from the fuel system . . . . .	7-42
Brakes . . . . .	9-4
<b>C</b>	
Commissioning operation . . . . .	4-1
Consumables . . . . .	7-3
Control panel switches . . . . .	3-6
Cuts and Damage in Wiring harness – Check . . . . .	7-32
<b>D</b>	
Diagnostic/Service tool port . . . . .	7-6
Diesel Oxidation Catalyst (DOC) assembly - Replace . . . . .	7-39
Drain off water and deposits from the fuel tank . . . . .	7-23
Drain water from hydraulic tank . . . . .	7-31
Drum bearing - Grease . . . . .	7-36
Drum oil - Replace . . . . .	7-32
<b>E</b>	
Ecology and the environment . . . . .	2-6
Electrical system . . . . .	9-4
Electrical systems - Check . . . . .	7-42
Electro-magnetic compatibility (EMC) . . . . .	1-2
Engine, canopy and Operator platform mounting bolts - Check . . . . .	7-21
Engine air filter primary and secondary element - Replace . . . . .	7-40
Engine and cooling pack mounting rubber pad - Check and replace . . . . .	7-33
Engine coolant level - Check . . . . .	7-12
Engine coolant - Replace . . . . .	7-37
Engine inspection door - Open/Close . . . . .	7-1
Engine mounting bolts - Check and tighten . . . . .	7-20
Engine oil and oil filter - Change . . . . .	7-26
Engine oil level and oil leakage - Check . . . . .	7-10
Engine oil temperature chart . . . . .	7-5
Engine parameter display - Check . . . . .	7-10
Engine specifications . . . . .	9-2
Engine - Troubleshooting . . . . .	8-1
Exciter drive . . . . .	9-3
Exhaust gas leakage check on all V band clamps . . . . .	7-33
Exhaust pipe mounting - Check and tighten . . . . .	7-32
<b>F</b>	
Fan / alternator belt - Replace . . . . .	7-41
Fan belt - Replace . . . . .	7-35
Fan belt tension - Check . . . . .	7-15
Fan mounting bolts - Check and tighten . . . . .	7-25

---

Forward controls . . . . .	3-4
Fuel filters - Replace . . . . .	7-27
Fuel hoses - Check and replace . . . . .	7-35
Fuel strainer - Clean . . . . .	7-30, 7-43
Fuel tank . . . . .	7-2
Fuel tank level - Check . . . . .	7-9
Functionality of controls and lamps . . . . .	7-14
<b>G</b>	
Gearbox - Troubleshooting . . . . .	8-7
General safety rules . . . . .	2-21
Grease points - Lubricate . . . . .	7-13
<b>H</b>	
Hand signals . . . . .	2-7
Hydraulic oil filter . . . . .	9-4
Hydraulic oil filter - Replace . . . . .	7-24
Hydraulic oil level - Check . . . . .	7-12
Hydraulic oil - Replace . . . . .	7-36
Hydraulic oil tank . . . . .	7-2
Hydraulic system breather - Cleaning . . . . .	7-20
Hydraulic systems - Troubleshooting . . . . .	8-4
<b>I</b>	
Instrument cluster panel . . . . .	3-12
Intended use . . . . .	1-2
<b>L</b>	
Lifting points . . . . .	5-3
<b>M</b>	
Machine and operator visibility . . . . .	4-8
Machine components . . . . .	1-9
Machine dimensions . . . . .	9-1
Machine orientation . . . . .	1-8
Maintenance chart . . . . .	7-7
Manual scope and required training level . . . . .	1-3
Mounting bolts of Roller, Front and rear cross beam, Side plates - Check and tighten . . . . .	7-18
Moving the unit . . . . .	4-7
<b>N</b>	
Note to the Owner . . . . .	1-1
<b>O</b>	
Operating the machine . . . . .	4-3, 6-5
Operating the machine at high altitudes . . . . .	6-1
Operating the machine at high temperatures and humidity . . . . .	6-1
Operating the machine at low temperatures . . . . .	6-2
Operating the machine during running-in period . . . . .	6-1
Operating the machine in extremely dusty environment . . . . .	6-2
Operating weights . . . . .	9-2
Operating with vibration on compacted and hard materials . . . . .	6-3
Operator's seat . . . . .	3-2
Operator platform, Canopy, Articulation joint mounting bolts - Check and tighten . . . . .	7-19
Organic Acid Technology (OAT) coolant . . . . .	7-4
<b>P</b>	
Parking brake . . . . .	7-14
Pre-filter - Replace . . . . .	7-25
Preventive maintenance . . . . .	7-1
Product Identification Number (PIN) . . . . .	1-5
Propulsion . . . . .	9-3
<b>R</b>	
Radiator, CAC - Cleaning whenever checked . . . . .	7-41

---

Radiator, HOC and CAC fins - Cleaning . . . . .	7-29
Radiator and CAC hoses and clamps - Check and tighten (if required) . . . . .	7-22
Radiator mounting bolts - Check and tighten . . . . .	7-28
Relief valve settings . . . . .	9-4

**S**

Safety rules . . . . .	2-2
Safety rules and signal word definitions . . . . .	2-1
Safety rules - Fuel handling precautions - Fuel handling precautions . . . . .	2-9
Safety rules - Specific precautions to this machine . . . . .	2-10
Safety rules - Utility precautions - Utility precautions . . . . .	2-9
Safety signs . . . . .	2-11
Scrapper - Adjust . . . . .	7-18
Short term storage . . . . .	7-45
Special torques. . . . .	9-5
Sprinkling . . . . .	9-4
Starter motor - Troubleshooting. . . . .	8-3
Starting the unit . . . . .	4-4
Steering system . . . . .	9-3
Stopping the unit . . . . .	4-6
Storing the engine . . . . .	7-45
Storing the machine. . . . .	7-44
Suction Strainer - Clean . . . . .	7-38

**T**

Taking the machine back to service . . . . .	7-48
Telematics . . . . .	1-2, 3-19
Torque specifications . . . . .	9-6
Towing the machine . . . . .	5-4
Transport dimensions . . . . .	5-1
Transporting on a trailer . . . . .	5-1
Travel Reduction gearbox oil - Replace . . . . .	7-23
Travel Reduction gear box oil - Replace . . . . .	7-34
Turbocharger mounting - Check . . . . .	7-33

**V**

Vandalism protection cover. . . . .	3-5
Vibration system . . . . .	9-2
Visual inspection . . . . .	7-14

**W**

Warnings and preliminary checking . . . . .	3-1
Water present in fuel filter - Check and Drain . . . . .	7-15
Water pump and its related mounting bracket bolts - Check and tighten . . . . .	7-24
Water pump safety measures in cold regions . . . . .	6-4
Water separator drain . . . . .	7-9, 7-39
Water sprinkling system - Cleaning . . . . .	7-42
Water tank . . . . .	7-3

Dealer's stamp

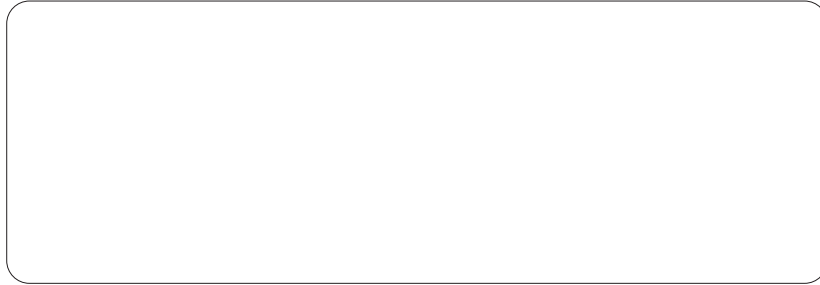

---

Case New Holland Construction Equipment (India) Pvt. Ltd. reserves the right to make improvements in design and changes in specification at any time without notice and without incurring any obligation to install them on units previously sold.

Specifications, descriptions, and illustrative material herein are as accurate as known at time of publication, but are subject to change without notice.

Availability of some models and equipment builds varies according to the country in which the equipment is being used. For exact information about any particular product, please consult your Case dealer.

© 2025 Case New Holland Construction Equipment (India) Pvt. Ltd.  
All rights reserved.

Case is a trademark registered in the United States and many other countries, owned by or licensed to CNH Industrial N.V., its subsidiaries or affiliates.

Any trademarks referred to herein, in association with goods and/or services of companies, other than owned by or licensed to CNH Industrial N.V., its subsidiaries or affiliates, are the property of those respective companies.

